

S A T L A N T I C

SUNA Manual

For SUNA running firmware version 2.5 or later

SAT-DN-00628, Rev. E, 2014-Dec-01

Satlantic LP
3481 North Marginal Road
Halifax, Nova Scotia B3K 5X8
Canada

+1 902 492 4780
info@satlantic.com
www.satlantic.com

C O N F I D E N T I A L

This document contains information proprietary to Satlantic or to a third party to which Satlantic may have legal obligation to protect such information from unauthorized disclosure, use or duplication. Any disclosure, use or duplication of this document in whole or in part, or of any of the information contained herein, for any purpose other than the specific purpose for which it was disclosed is expressly prohibited except as Satlantic may otherwise agree to in writing.

© 2013, Satlantic LP, All rights reserved

SUNA Manual
For SUNA running firmware version 2.5 or later

Table of Contents

1. About This Manual.....	5
2. Start-up Guides.....	6
2.1 Start-up Guide for Terminal Interface.....	6
2.2 Start-up Guide for SDI-12 Interface.....	7
2.3 Start-up Guide for Analog Output.....	8
3. The SUNA Sensor.....	9
3.1 Introduction and Background.....	9
3.2 Specifications.....	9
3.2.1 Build Variants.....	9
3.2.2 Electrical Specification.....	13
3.2.3 Performance Specifications.....	14
3.3 Operating Principles.....	17
3.3.1 Absorbance Spectroscopy.....	17
3.3.2 Nitrate Concentration.....	18
3.3.3 Interferences and Mitigation.....	18
4. Terminal Interface of the SUNA.....	20
4.1 Sensor Operating States.....	20
4.2 Command Line Interface.....	20
4.2.1 Status and Maintenance Commands.....	21
4.2.2 File Commands.....	22
4.2.3 Configuration Commands.....	23
4.2.4 Polled Mode Commands.....	38
4.2.5 SDI-12 Mode Commands.....	38
4.2.6 Analog Output.....	42
5. Configuration Parameters in Context.....	46
5.1 Build Configuration.....	46
5.2 Input / Output Configuration.....	47
5.3 Data Acquisition Configuration.....	48
5.3.1 Continuous and Fixed-time Operating Mode.....	48
5.3.2 Periodic Operating Mode.....	49
5.3.3 Polled Operating Mode.....	49
5.3.4 SDI-12 Operating Mode.....	50
5.4 Data Processing Configuration.....	51
5.4.1 Basic Data Processing.....	51
5.4.2 Special Case: Bromide Tracing.....	51
5.4.3 Special Case: Highly Absorbing Water.....	51
6. Use Scenarios.....	53
6.1 Profiling.....	53
6.1.1 Objectives and Considerations.....	53

SUNA Manual
For SUNA running firmware version 2.5 or later

6.1.2 Example.....	53
6.2 Moored.....	54
6.2.1 Objectives and Considerations.....	54
6.2.2 Example.....	55
7. SUNA Frame Definitions.....	57
7.1 Frames with Synchronization Headers.....	57
7.2 APF Frame.....	58
7.3 MBARI Frame.....	60
8. SUNA Calibration File.....	61
8.1 File Name.....	61
8.2 File Format.....	61
8.3 File Interpretation.....	61
9. Firmware Upgrade.....	62
9.1 Firmware Upgrade Using SUNACom.....	62
9.2 Firmware Upgrade Using the Terminal Interface.....	62
10. Troubleshooting.....	63
10.1 Sensor Is Not Responsive.....	63
10.2 Sensor Output Is Unexpected.....	64
11. Accessories.....	65
11.1 Foul Guard.....	65
11.2 Wiper.....	65
11.3 Flow Cell.....	67
12. Maintenance.....	68
13. Safety And Hazards.....	69
13.1 Pressure Hazard.....	69
13.2 Electrical Hazard.....	69
13.3 Deployment and Recovery Safety.....	69
14. Warranty.....	70
14.1 Warranty Period.....	70
14.2 Restrictions.....	70
14.3 Provisions.....	70
14.4 Returns.....	70
14.5 Liability.....	70
15. Contact Information.....	71
16. Revision History.....	72

Index of Tables

Table 1: Sensor dimensions, basic options.....	9
Table 2: Optional features.....	10
Table 3: SUNA dimensions depending on options.....	10
Table 4: Power requirements.....	13

SUNA Manual
For SUNA running firmware version 2.5 or later

Table 5: Electrical pin assignments and descriptions.....	14
Table 6: General performance specifications.....	15
Table 7: Accuracy specification for nitrate concentrations.....	15
Table 8: Precision specification for nitrate concentrations.....	16
Table 9: Limit of Detection and Limit of Quantification.....	16
Table 10: File access commands.....	22
Table 11: Build configuration parameters.....	26
Table 12: Input / output configuration parameters.....	29
Table 13: Data acquisition configuration parameters.....	34
Table 14: Data processing configuration parameters.....	37
Table 15: Combinations of data processing configuration parameters.....	37
Table 16: SUNA build variants.....	46
Table 17: Data acquisition configuration parameters by operating mode.....	50
Table 18: Data processing configuration parameters in use case context.....	52
Table 19: Configuration parameters illustrating a profiling deployment.....	54
Table 20: Configuration parameters illustrating a moored deployment.....	56
Table 21: Synchronization header frame definitions.....	58
Table 22: APF data frame definition.....	59
Table 23: MBARI data frame definition.....	60

Index of Illustrations

Illustration 1: Drawing of Standard SUNA with 10 mm path length.....	11
Illustration 2: Drawing of Standard SUNA with 5 mm path length.....	11
Illustration 3: Drawing of Standard SUNA with 10 mm path length and wiper.....	12
Illustration 4: Drawing of Standard SUNA with 5 mm path length and wiper.....	12
Illustration 5: SUNA SubConn MCBH8MNM bulkhead connector face view.....	13
Illustration 6: Foul Guard.....	64
Illustration 7: SUNA with integrated wiper.....	65
Illustration 8: Space requirements for the integrated wiper.....	65
Illustration 9: Flow Cell.....	66

SUNA Manual
For SUNA running firmware version 2.5 or later
1. About This Manual

1. About This Manual

The SUNA is a versatile sensor that can operate in diverse environments. It is adaptable to a wide variety of deployment scenarios and supports multiple interfaces. This manual provides guidance on how to properly deploy the sensor and on how to interact with it.

Before operating the sensor, understand all warnings and cautions cited in section 13. Safety And Hazards.

Section 3. The SUNA Sensor gives performance specifications, sensor dimensions, and explains the measurement technology.

The SUNACom software provides a graphical user interface to facilitate working with the sensor. It supports sensor configuration, system testing, data management, and data re-processing. SUNACom has a separate user manual, which is available on the installation CD and from within the SUNACom application via context sensitive help.

SUNACom does not address the requirements for all deployment scenarios, particularly those related to integrated systems. For this reason, the complete firmware interface is specified in Section 4. Terminal Interface of the SUNA. Explanations on how to start when working in this environment are found in Section 2.1 Start-up Guide for Terminal Interface.

The decision on how to configure the sensor is driven by the type of deployment. Section 5. Configuration Parameters in Context provides an explanation of configuration parameters. Section 6. Use Scenarios discusses configuration choices for some types of deployments, and Section 7. SUNA Frame Definitions defines the output data.

Components supporting the deployment of the SUNA are specified in Section 11. Accessories.

Some deployments benefit from components that can be added to the SUNA.

The SUNA is a versatile sensor and research is ongoing to expand its performance and use. Support of new features can be coded into future SUNA firmware versions. Section 9. Firmware Upgrade provides instructions on how to install such a new firmware.

Explanation and remediation for some unexpected behavior of the SUNA are addressed in Section 10. Troubleshooting, and guidance on handling is provided in Section 12. Maintenance.

SUNA Manual
For SUNA running firmware version 2.5 or later
2. Start-up Guides

2. Start-up Guides

Refer to the **Quick Start** section of the SUNACom User manual available on your installation CD or bundled with the SUNACom software to test basic operation and configuration. The following start-up guides will guide you through the process of connecting to interfaces not available via SUNACom.

2.1 Start-up Guide for Terminal Interface

Terminal Emulator

The end user can interface with the SUNA by using terminal emulator software that can connect to a serial com port. Some computers have pre-installed terminal emulators (e.g., HyperTerm in some Microsoft Windows operating systems). Other terminal emulators are, e.g., Putty, Tera Term, Bray's Terminal. This guide assumes that the user is familiar with operating a terminal emulator.

Cable

In order to use the terminal interface, connect the sensor's serial cable to a com port of the computer, and power the sensor with 8–18 VDC (8–15 VDC for SUNA with an integrated wiper), capable of providing a current of at least 1 A.

Serial Interface

The SUNA communicates via serial port, using the RS-232 protocol at 8 bit, no parity, 1 stop bit and no flow control. The baud rate is factory set to 57600. If this baud rate does not work, try the other possible baud rates (9600, 19200, 38400, 115200) or use SUNACom to scan for the current baud rate.

Command Line

When power is applied to the SUNA, output and behavior depend on the current sensor configuration. In all instances the user can bring the sensor to the command line by repeatedly sending the \$-character to the sensor.

The sensor indicates that it is accepting commands by outputting the `SUNA>` prompt. All commands available at the command line are given in section 4.2 Command Line Interface.

An example command is `selftest`. It turns on all subsystems and briefly reports their status.

Using the `get opermode` command will report the current operation mode. Consult section 5.3 Data Acquisition Configuration to understand the different operating modes, and use the `set opermode` command if another operating mode is needed. Use the `get cfg` command for the current sensor configuration.

SUNA Manual
For SUNA running firmware version 2.5 or later
2. Start-up Guides

2.2 Start-up Guide for SDI-12 Interface

The SUNA has an optional SDI-12 interface.

Use SUNACom or the terminal interface to find out if the sensor is equipped with the SDI-12 Interface.

Within SUNACom verify the SDI-12 is listed as one of the options under the Operational Mode of the SUNA Settings display. See the SUNACom user manual for details.

At the terminal interface, use the `get sdi12brd` command. The response will be either `Available` or `Missing`.

Start SDI-12 Operation

SUNA sensors are not factory set to operate in SDI-12 mode. To operate the sensor as a SDI-12 device, it first has to be configured to do so.

In SUNACom select SDI-12 as the operating mode under the SUNA Settings display and Upload. See the SUNACom user manual for details.

At the terminal interface, use the `set opermode SDI12` command.

Data Processing

Before deployment, the user should confirm that the data processing configuration is suitable for the expected deployment. See section 5.4 Data Processing Configuration for details.

Deployment

After the sensor has been configured to run in SDI-12 operation mode, and processing has been configured, the sensor can be rebooted or power cycled. At this point, the sensor will respond to SDI-12 commands. For supported SDI-12 commands, see section 4.2.5 SDI-12 Mode Commands.

End SDI-12 Deployment

In order to bring the sensor out of SDI-12 mode, either use SUNACom or the terminal interface.

In SUNACom select another operating mode under the SUNA Settings display and Upload. See the SUNACom user manual for details.

In the latter case, sending the `$` character brings the sensor to the command line, and allows the user to switch to another operating mode via the `set opermode` command.

SUNA Manual
For SUNA running firmware version 2.5 or later
2. Start-up Guides

2.3 Start-up Guide for Analog Output

The SUNA has an optional analog output system.

The end user can determine if the sensor is equipped for analog output either via the SUNACom software or the terminal interface (see section 2.1 Start-up Guide for Terminal Interface and section 4. Terminal Interface of the SUNA).

In SUNACom the DAC calibration function will be visible under the Advanced, Sensor menu item if this function is available.

At the terminal interface, use the `get analgbrd` command. The response will be either `Available` or `Missing`.

Interpreting Analog Output

When analog output is available, the sensor automatically generates output voltage and current.

The sensor generates an output voltage in the 0 to 4.096 V and an output current in the 4 to 20 mA range. The lower range of the respective output interval corresponds to the DAC Minimum and the upper range of the interval corresponds to the DAC Maximum configuration parameter.

Both the DAC minimum and DAC maximum values can be modified, either via SUNACom or via the terminal interface, to tune the output range to the expected nitrate concentration range.

While the output voltage and current generated by the sensor are highly accurate, losses may occur across cables that are used. For details on calibration and data interpretation, see section 4.2.6 Analog Output.

SUNA Manual
For SUNA running firmware version 2.5 or later
3. The SUNA Sensor

3. The SUNA Sensor

3.1 Introduction and Background

The SUNA (Submersible Ultraviolet Nitrate Analyzer) is a chemical-free nitrate sensor.

It is based on the ISUS (In Situ Ultraviolet Spectroscopy) technology developed at MBARI (cf. Kenneth S. Johnson, Luke J. Coletti, In situ ultraviolet spectrophotometry for high resolution and long-term monitoring of nitrate, bromide and bisulfide in the ocean, Deep-Sea Research I 49 (2002) 1291–1305).

3.2 Specifications

3.2.1 Build Variants

The SUNA housing is made from acetal, and is suitable for deployments of up to 500 m depth, or 100 m depth with the optional integrated wiper.

Table 1: Sensor dimensions, basic options.

Dimension	Basic Variant
Material	Acetal / Titanium
Depth Rating	500 m 100 m (integrated wiper)
Diameter	63 mm
Length (without connector and anode)	567 mm
UV Deuterium Lamp	900 h lifetime
Path length	10 mm
Displacement	1749 cm ³
Weight	2.5 kg
Electrical connector	SubConn MCBH8MNM
Storage temperature	–20 to +50 C
Operating temperature	--2 to +35 C

SUNA Manual
For SUNA running firmware version 2.5 or later
3. The SUNA Sensor

Optional features and accessories change some sensor dimensions, as shown below.

Table 2: Optional features

Feature / Accessory	Comment
Reduced path length	5 mm
Calibration	Normal: NO3 only Optional: NO3 & seawater
Analog output	Optional
SDI-12 interface	Optional
Internal data logging	Optional 2 GB (or larger) solid state
Scheduling	Optional
USB connectivity	Optional
Active fouling control	Integrated wiper
Passive fouling control	Copper fouling guard
Sampling control	Flow through cell
Power supply	Battery pack

Table 3: SUNA dimensions depending on options.

Options	Length	Displacement	Weight
Standard SUNA, basic variant	567 mm	1749 cm ³	2.5 kg
Standard SUNA, 5 mm path length	562 mm	1745 cm ³	2.5 kg
Standard SUNA, integrated wiper	588 mm	2092 cm ³	3.1 kg
Standard SUNA, 5 mm path length, integrated wiper	583 mm	2084 cm ³	3.1 kg

3. The SUNA Sensor

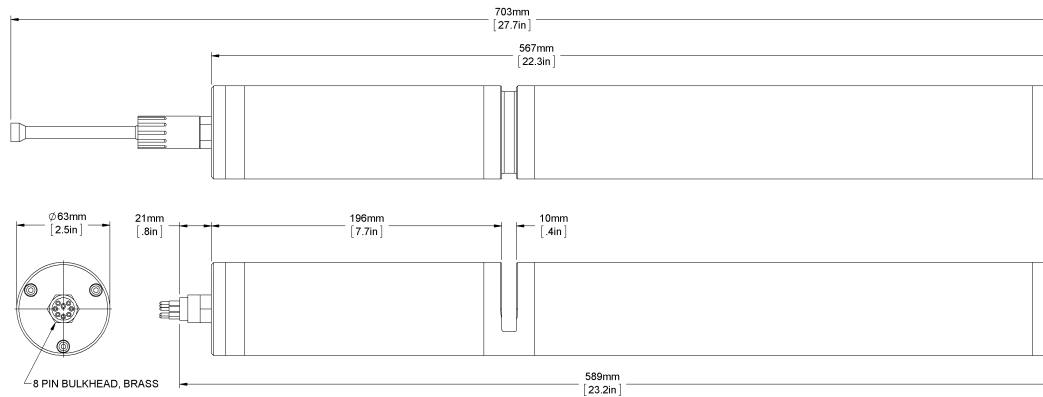

Illustration 1: Drawing of Standard SUNA with 10 mm path length.

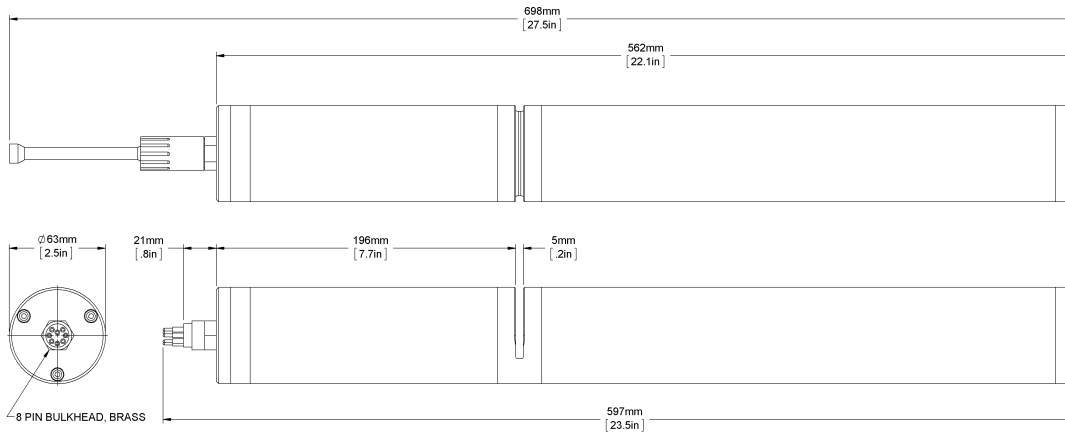

Illustration 2: Drawing of Standard SUNA with 5 mm path length.

SUNA Manual

For SUNA running firmware version 2.5 or later

3. The SUNA Sensor

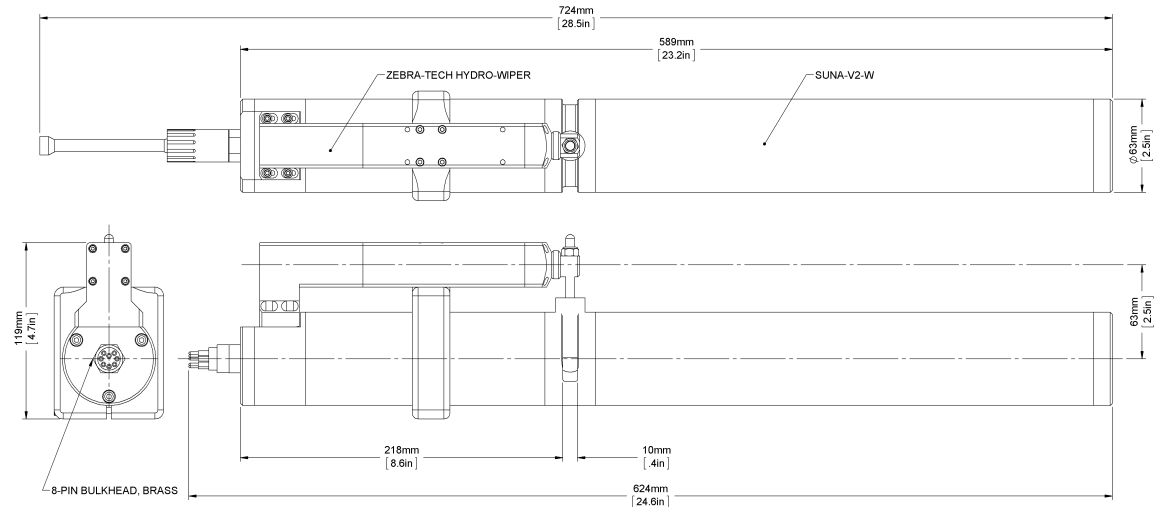

Illustration 3: Drawing of Standard SUNA with 10 mm path length and wiper.

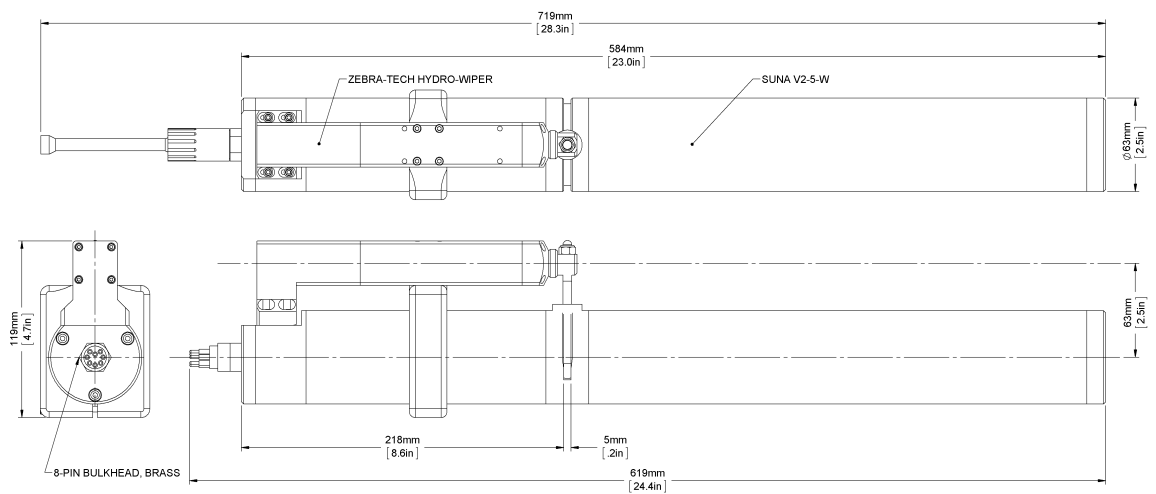

Illustration 4: Drawing of Standard SUNA with 5 mm path length and wiper.

SUNA Manual
For SUNA running firmware version 2.5 or later
3. The SUNA Sensor

3.2.2 Electrical Specification

The SUNA requires power in the 8–18 VDC range with a supply current of 1 A (8–15 VDC for SUNA with an integrated wiper). Power consumption depends on the operating state. During data acquisition, it is typically 7.5 W ($\pm 20\%$). In standby, at the command prompt, the current draw is around 20 mA.

Polled and APF operating modes will time out after a configurable time of inactivity, bringing the SUNA processor into a low power state with a consumption below 3 mA. In fixed-time operation and between periodic operation event, power control is handed to a supervisor circuit, which reduces power consumption to less than 30 μ A.

Table 4: Power requirements

State	Voltage	Current
Supervised Sleep	8–18 VDC (8–15 VDC with integrated wiper)	< 30 μ A
Processor Sleep		< 3 mA
Standby		~20 mA at 12 V
Sampling		~625 mA at 12 V (nominal)

The SUNA connector is a SubConn MCBH8MNM. With a face view numbering as in the following illustration, the pin assignments are listed in the following tables.

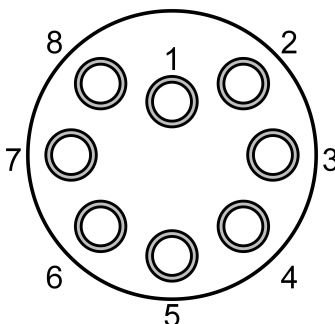

Illustration 5: SUNA SubConn MCBH8MNM bulkhead connector face view.

SUNA Manual
For SUNA running firmware version 2.5 or later
3. The SUNA Sensor

Table 5: Electrical pin assignments and descriptions.

Pin	Standard	Optional USB / Analog Out
1	VIN	VIN
2	GND	GND
3	–	USB V+
4	–	SDI-12
5	TXD	TXD / D+
6	RXD	RXD / D–
7	–	VOUT
8	–	IOUT
Pin Assignment	Description	
VIN	External DC power supply, 8–18 VDC or 8–15 VDC	
GND	Power supply return, signal ground	
USB V+	USB 5V power	
SDI-12	Serial data interface at 1200 baud	
TXD	RS-232 transmit (from SUNA)	
RXD	RS-232 receive (to SUNA)	
D+	USB D+	
D–	USB D–	
VOUT	Analog volt output	
IOUT	Analog current output	

3.2.3 Performance Specifications

The SUNA sensor is designed to measure the concentration of nitrate ions in water. The measurement result is in molar concentration, units of micro molar (μM). For user convenience, this concentration is converted into units of milligram per liter (mg/l), and output in digital form as well. 1 μM nitrogen corresponds to 0.014007 mg/l nitrate.

SUNA Manual
For SUNA running firmware version 2.5 or later
3. The SUNA Sensor

Table 6: General performance specifications

Measurement	Nitrate concentration [NO ₃]
Thermal compensation (optional)	0–35°C
Salinity compensation (optional)	0–40 psu
Optical path length	10 mm, optional 5 mm
Spectral range	190–370 nm

The performance of the sensor depends on a number of factors. One factor is the optical path length, normally at 10 mm, optionally at 5 mm. The optical path length influences the concentration measurement range covered by the sensor, and the accuracy of the results. Another factor is the type of calibration: a sensor specific calibrations are more accurate than a class-based calibration. The former uses extinction coefficients that are measured using the sensor itself; the latter uses averaged extinction coefficients, that were obtained from many sensors.

Table 7: Accuracy specification for nitrate concentrations

Concentration Range	10 mm Path Length	5 mm Path Length
For regular seawater and freshwater calibrations		
up to 1000 µM	2 µM or 10%	4 µM or 10%
up to 2000 µM	2 µM or 15%	4 µM or 15%
up to 3000 µM	2 µM or 20%	4 µM or 15%
up to 4000 µM	out-of-range	4 µM or 15%
For class-based freshwater calibrations		
up to 1000 µM	2.5 µM or 20%	4.5 µM or 20%
up to 2000 µM	2.5 µM or 25%	4.5 µM or 25%
up to 3000 µM	2.5 µM or 30%	4.5 µM or 25%
up to 4000 µM	out-of-range	4.5 µM or 25%

The precision of the sensor depends on its data processing configuration (see section 5.4 Data Processing Configuration). In oceanographic or estuarine settings, data must be processed for seawater, in freshwater settings data processing is ideally selected to be for freshwater. In seawater settings, the sensor precision can be brought into the freshwater precision by post-processing in SUNACom with Temperature-Salinity-Correction applied.

SUNA Manual
For SUNA running firmware version 2.5 or later
3. The SUNA Sensor

Table 8: Precision specification for nitrate concentrations

Processing configuration	Freshwater or Seawater with T-S-Correction	Seawater [0–40 psu]
Short-term precision [at 3 σ]	0.3 μ M	2.4 μ M
Drift [per hour of lamp time]	<0.3 μ M	<1.0 μ M

The limit of detection is defined as the nitrate concentration that has a value of 3 times the standard deviation of the blank nitrate concentration. As such, it is 3 times the standard deviation as measured for the sensor precision, which depends on the processing mode.

The limit of quantification specifies the limit at which two samples can be reasonably distinguished. Typically, it is 10 times the standard deviation of the blank nitrate concentration.

Table 9: Limit of Detection and Limit of Quantification

Processing configuration	Freshwater or Seawater with T-S-Correction	Seawater [0–40 psu]
Limit of detection [LOD]	0.3 μ M	2.4 μ M
Limit of quantification [LOQ]	1.0 μ M	8.0 μ M

Natural waters may contain a mixture of interfering species that are typically hard to delineate. The impact of interfering species on the measured nitrate concentration was determined under laboratory conditions. The specification covers two classes of interfering species: suspended particulate matter (Turbidity) and colored dissolved organic matter (CDOM). The impact is independent of the optical path length, from theoretical considerations as well as experimentally confirmed. However, the SUNA can only operate up to absorbances of approximately 1.5. This limit is typically reached at 625 NTU (Nephelometric Turbidity Units) for 10 mm path length, or at 1250 NTU for 5 mm path length. Naturally occurring CDOM concentrations stay within the operating range of the SUNA.

The following substances were used as proxies for turbidity:

- ARD Arizona Road Dust
- Kaolin Kaolin Powder
- TiO₂ Titanium Dioxide

SUNA Manual
For SUNA running firmware version 2.5 or later
3. The SUNA Sensor

<i>Turbidity Sample</i>	<i>NTU per mg/l</i>	<i>Absorbance at 225 nm (10 mm) per mg/l</i>	<i>NO3 shift μM in freshwater per mg/l</i>	<i>NO3 shift μM in seawater per mg/l</i>
ARD	1.25	0.0016	<-0.002	0.01
Kaolin	1.5	0.0085	<0.001	0.02
TiO2	15.0	0.0090	<0.001	<0.001

The following samples, obtained from the International Humic Substances Society, were used as proxies for CDOM:

- PLFA Pony Lake Fulvic Acid – Reference (1R109F)
- SRFA Suwannee River Fulvic Acid – Standard (1S101F)
- PPHA Pahokee Peat Humic Acid – Reference (1R103H-2)

<i>CDOM Sample</i>	<i>QSD per mg/l</i>	<i>Absorbance at 225 nm (10 mm) per mg/l</i>	<i>NO3 shift μM in freshwater per mg/l</i>	<i>NO3 shift μM in seawater per mg/l</i>
PLFA	N/A	0.017	0.4	0.6
SRFA	N/A	0.027	<0.1	<0.1
PPHA	42	0.003	<0.01	<0.1

An interfering species generates a spurious nitrate concentration when the spectral characteristics of the interfering species resembles that of nitrate. Typically, an RMSE value that is more than a few times the RMSE of a pure nitrate sample should be taken as an indication that interfering species are impacting the measurement. The RMSE value is the square root of the mean of the sum of the squared differences between the measured and the fitted absorbance; it provides a measure for the quality of the fit. Independent measurements of turbidity and CDOM, as well as an analysis of the absorption spectrum, can refine the impact analysis.

3.3 Operating Principles

3.3.1 Absorbance Spectroscopy

The SUNA measures the concentration of dissolved nitrate in water. The sensor illuminates the water sample with its deuterium UV light source, and measures the throughput using its photo-spectrometer. The difference between this measurement and a prior baseline reference measurement of pure water constitutes an absorption spectrum.

SUNA Manual
For SUNA running firmware version 2.5 or later
3. The SUNA Sensor

Absorbance characteristics of natural water components are provided in the sensor calibration file. The Beer-Lambert law for multiple absorbers establishes the relationship between the total measured absorbance and the concentrations of individual components. Based on this relationship, the sensor obtains a best estimate for the nitrate concentration using multi-variable linear regression.

The approach described above was initially developed at MBARI (cf. Kenneth S. Johnson, Luke J. Coletti, In situ ultraviolet spectrophotometry for high resolution and long-term monitoring of nitrate, bromide and bisulfide in the ocean, Deep-Sea Research I 49 (2002) 1291–1305) and the technology then transferred to Satlantic.

3.3.2 Nitrate Concentration

Nitrate processing uses the 217–240 nm wavelength interval, which contains approximately 35 spectrometer channels. For each channel, the absorbance is calculated, and decomposed into individual absorbers using the MBARI method.

The precision of the nitrate concentration depends on the number of absorbers into which the measured absorbance is decomposed. Thus, in freshwater deployments, the number of concentrations to be fitted should be set to 1.

High absorbance conditions introduce inaccuracies into the nitrate concentrations. Therefore, channels with an absorbance greater than 1.3 are excluded from processing. If less than about 10 channels remain, the sensor is unable to determine a nitrate concentration, and the measurement is no longer valid (out-of-bounds). Users can overturn the standard setting and increase the absorbance cutoff, obtaining reduced accuracy nitrate concentrations at higher absorbances. There is, however, a limit at around 2.5 absorbance units, when nitrate concentrations can no longer be determined.

3.3.3 Interferences and Mitigation

The quality of the nitrate measurements can be impacted in a number of ways. This impact has been quantified (see section 3.2.3 Performance Specifications) for some significant interfering influences. Here, interferences are explained, and mitigation options are explored.

Sample temperature: Seawater is known to have a temperature-dependent absorption. If this effect is not taken into account, a bias and/or imprecision are introduced to the reported nitrate concentration.

This effect can be mitigated by providing sample temperature and salinity to the nitrate calculation, either in real-time (supported in APF mode) or in SUNACom post-processing (collection of spectra and accompanying temperature and salinity data is required). Temperature-salinity correction follows the approach developed at MBARI (cf. Carole M. Sakamoto, Kenneth S. Johnson, Luke J. Coletti, Improved algorithm for the computation of nitrate concentrations in seawater using an in situ ultraviolet spectrophotometer, *Limnol. Oceanogr.*: Methods 7, 2009, 132–143).

SUNA Manual
For SUNA running firmware version 2.5 or later
3. The SUNA Sensor

Uncharacterized species in sample: A number of substances occurring in natural water absorb in the UV spectral range where nitrate absorbs. Usually, the spectral signature of those substances differs from that of nitrate. However, certain combinations of water constituents may cause a bias in the calculated nitrate concentrations.

If significant concentrations of interfering species are suspected, sporadic chemical analysis of water samples allows quantification and correction for the optical interference.

Sensor drift: Over time, lamp output and throughput of optical components exhibit drift. This drift translates into a drift in the measured nitrate concentrations.

A regular update of the reference (baseline) spectrum minimizes drift.

Lamp temperature: The lamp output depends on its temperature. Thus, the reference (baseline) spectrum is ideally collected under conditions that mimic deployment conditions.

If deployment temperatures are expected to vary by more than 10 °C, a temperature characterization and subsequent data correction may be attempted.

Optically dense constituents: The sensor performance is compromised in optically dense conditions, which transmit less light than necessary for the regression analysis. With increasing optical density, the quality of the measurement (signal-to-noise) decreases. Accuracy and precision of the nitrate concentrations decrease with decreasing data quality, until the data are essentially random (or are reported as out-of-range, depending on sensor configuration).

The sensor can be configured to respond to optically dense conditions by repeating the measurement with an increased spectrometer exposure time, thereby extending the operating range of the sensor.

High optical densities are often caused by CDOM or turbidity in the water sample. It has been found that the CDOM concentration in natural waters does not cause optical extinction. On the other hand, highly turbid waters can cause such high absorption that the SUNA is not able to measure nitrate. The operation limit for the 10 mm path length variant is 625 NTU, and for the 5 mm variant it is 1250 NTU.

4. Terminal Interface of the SUNA

4.1 Sensor Operating States

At power-up, the SUNA's micro-controller starts the firmware. After initialization, it retrieves the current settings, and enters its operating mode.

Within each operating mode, the firmware is in one of three states:

- standby,
- data acquisition,
- command interface,

where the transition between the states is controlled by the firmware or driven by user or controller input.

In standby, the sensor can be at different levels of power consumption. In periodic and APF mode, the sensor achieves the lowest level between data acquisition events, whereas in polled mode, the power level is a bit higher, and in SDI-12 mode, the power level is identical to the one when the sensor is at the command line.

The user can interrupt the SUNA's regular operation in order to enter the command line.

Data Acquisition to Command Interface

Sending a \$ character (possible multiple times) will bring the sensor to the command line. The command line reports via the SUNA> prompt that it is ready to receive commands.

Command Interface to Data Acquisition

The command line is terminated via the `exit` or the `reboot` command.

Data Acquisition to Standby

Only polled and APF modes have explicit commands (SLEEP and SLP, respectively) to send the SUNA to standby mode.

In periodic mode, the sensor alternates between standby and data acquisition.

Standby to Data Acquisition

Any input will cause the SUNA to come out of its standby state. Then, it waits for 15 seconds for the \$ input character to enter the command line, before returning to the standby state. When entering standby, the sensor requires approximately 15 seconds to completely discharge its internal circuitry. Any attempt to bring the sensor out of its standby state occurring within this 15 second period can lead to undefined behaviour.

4.2 Command Line Interface

Communication with the SUNA is conducted via RS-232 or USB connection. The sensor

SUNA Manual
For SUNA running firmware version 2.5 or later
4. Terminal Interface of the SUNA

checks for availability of a USB connection, and if present, uses a USB virtual com port for input and output. Otherwise, the sensor communicates via RS-232.

Commands can be broadly grouped into the following categories:

1. Status and Maintenance
2. File Management
3. Query and Modify Configuration
4. Polled Mode Commands
5. APF Mode Commands
6. SDI-12 Mode Commands

4.2.1 Status and Maintenance Commands

Selftest

The selftest checks operation of sensor components, performs measurements, and outputs the measurement results.

The last output line will be `$Ok` if all components performed according to expectations, or `$Error` if one or more of the components failed the test. If a component did not perform as expected, the output line of that component is terminated by an exclamation mark (!), making it easier to locate the problem.

Get Clock and Set Clock

The `get clock` command outputs the time of the internal sensor clock. The time is factory set to UTC.

The `set clock YYYY/MM/DD hh:mm:ss` command sets the sensor clock to the specified value.

Used Lamp Time

The firmware keeps track of the total on-time of the lamp, and outputs the number of seconds via the `get lamptime` command.

Wiper Test

The firmware provides the `special swipewiper` command to run the wiper one time.

DAC Low and DAC High

These commands are only available for SUNAs that have an analog output system.

SUNA Manual
For SUNA running firmware version 2.5 or later
4. Terminal Interface of the SUNA

The `DAC Low` command will generate the lowest analog output that is possible, and the `DAC High` command will generate the highest analog output that is possible.

For details on how to make use of this feature, see section 4.2.6 Analog Output.

Upgrade

The firmware exits into the boot loader.

The boot loader allows installing of a new firmware onto the nitrate sensor. See section 9. Firmware Upgrade for details.

Reboot

This command causes the firmware to restart. It is equivalent to performing a power cycle.

Exit

The command line exits, and data acquisition as configured in the operation mode restarts. If the baud rate was changed in the current command line session, the sensor will reboot in order to re-initialize with the new baud rate.

4.2.2 File Commands

File commands give access to data log, message log, and calibration files. All file commands follow the syntax `<Command> <FileType> [<FileName>]`. Data and message log files are an optional feature. Use the `selftest` command to see if the sensor has an internal file system, and if so, the space that is available.

File types are `CAL` for calibration files, `LOG` for system log message files, and `DATA` for files containing logged measurement data.

Table 10: File access commands

Command	CAL	LOG	DATA	Comment
List	+	+	+	Output a list of all files of the specified type
Output	+	+	+	Output the content of the specified file. Recommended only for small ASCII files. The command cannot be interrupted.
Send	+	+	+	XMODEM transfer of file from sensor
Delete	+	+	+	Delete specified file from disk. Irreversible.
Receive	+			XMODEM transfer of file to sensor

The sensor can have many calibration files. The user can query the name of the

SUNA Manual
For SUNA running firmware version 2.5 or later
4. Terminal Interface of the SUNA

currently active file via the `get activecalfile` command. The active file cannot be deleted from the sensor. When a calibration file is received by the sensor, it is made active. The user can change the active file by the `set activecalfile calfile-name` command.

4.2.3 Configuration Commands

Configuration commands allow the user to query and modify configuration parameters.

The commands follow the syntax

```
get --<short name>
set --<short name> <value>
setrange --<short name> <value>,<value>
```

Below is a list of all configuration parameters with a brief explanation. Each subsection finishes with a table containing the parameters, the range of accepted values, and the short name for accessing the parameter using the above commands.

The `setrange` command only applies to the two pairs of wavelength values.

Build Configuration

All build parameters are for information only, and cannot be modified.

Sensor Type

The Sensor Type is **SUNA**.

Sensor Version

The Sensor Version is **V2**.

Serial Number

The Serial Number is factory set.

Sensor Brand

The Sensor Brand is **Satlantic**.

Super Capacitors

The super capacitors are either **Available** or **Missing**.

During start-up, the capacitors are charged to provide brief internal power in the event of a sudden power loss. Internal backup power allows the sensor to shut down into a safe state.

The disadvantage of super capacitors is an increased total power consumption.

SUNA Manual
For SUNA running firmware version 2.5 or later
4. Terminal Interface of the SUNA

PCB Supervisor

The PCB supervisor circuit is either **Available** or **Missing**.

Sensors are optionally equipped with the PCB supervisor, which allows the sensor to enter power saving mode.

USB Communication

The USB communication is either **Available** or **Missing**.

Sensors are optionally equipped with USB communication. Sensors can always communicate via RS-232. If USB is available and plugged in, communication switches to USB.

Relay Module

The relay module is **Missing**.

This feature is only available in the Deep SUNA.

SDI-12 Interface

The SDI-12 interface is either **Available** or **Missing**.

Sensors are optionally equipped with the SDI-12 interface.

Analog Output

The analog output system is either **Available** or **Missing**.

Sensors are optionally equipped with analog output system.

Internal Data Logging

Internal data logging is either **Available** or **Missing**.

Sensors are optionally equipped with memory for internal data logging.

APF Interface and Temperature-Salinity Correction

The APF interface and temperature-salinity correction is **Missing**.

This feature is only available in the Deep SUNA.

Scheduling

The scheduling capability is either **Available** or **Missing**.

Sensors are optionally capable to run on a configured schedule.

SUNA Manual
For SUNA running firmware version 2.5 or later
4. Terminal Interface of the SUNA

Optical Path Length

The optical path length is **5mm** or **10mm**.

Integrated Wiper

The integrated wiper is **Available** or **Missing**.

When a wiper has been integrated into the sensor, control of the wiper operation is enabled.

External Power Port

The external power port is **Missing**.

An external power port may be supported in future SUNA versions.

Addresses of Temperature Sensors

The addresses of the three SUNA internal temperature sensors are factory configured, and provided for troubleshooting.

Spectrometer Serial Number

The spectrometer serial number is factory configured.

Lamp Serial Number

The lamp serial number is factory configured.

Lamp Use Power

The power used by the sensor when the lamp is turned on in units of milliwatt [mW]. It is measured during sensor assembly, and serves as a reference point for the firmware to ascertain that the lamp is operating properly. It also allows to estimate the sensor's power consumption.

Custom ID

The Custom Identification string allows operators to assign their own identification to a SUNA. The string can be up to 15 ASCII characters long.

SUNA Manual
For SUNA running firmware version 2.5 or later
4. Terminal Interface of the SUNA

Table 11: Build configuration parameters

Parameter	Possible Values	Short Name
Sensor Type	SUNA	senstype
Sensor Version	V2	sensvers
Serial Number	1–9999	serialno
Sensor Brand	Satlantic	thebrand
Super Capacitors	Available, Missing	suprcaps
PCB Supervisor	Available, Missing	pwrsvizr
USB Communication	Available, Missing	usbwtch
Relay Module	Missing	relaybrd
SDI-12 Interface	Available, Missing	sdil2brd
Analog Output	Available, Missing	analgbrd
Internal Data Logging	Available, Missing	intdatlg
APF Interface	Missing	apfiface
Scheduling	Available, Missing	schdling
Optical Path Length	5mm, 10mm	pathlgth
Integrated Wiper	Available, Missing	intwiper
External Power Port	Missing	extpport
Address of lamp temperature sensor		owiretlp
Address of spectrometer temperature sensor		owiretsp
Address of housing temperature sensor		owireths
Spectrometer Serial Number		zspec_sn
Lamp Serial Number		fiberlsn
Lamp Use Power [mW]		lmpusepw
Custom ID	String, up to 15 characters	customid

Input and Output Configuration

Baud Rate

The baud rate is one of 9600, 19200, 38400, **57600**, or 115200.

A changed baud rate takes effect after the next power-up or reboot.

SUNA Manual
For SUNA running firmware version 2.5 or later
4. Terminal Interface of the SUNA

Message Level

The message level is one of Error, Warn, **Info**, Debug, Trace.

Messages are sent to the output stream and are also saved in a message log file.

Message File Size

The message file size is in the 0 to 65 MB range, and initially set to **2 MB**.

Setting the file size to zero turns off logging of messages to file.

Data File Size

The data file size is in the 1 to 65 MB range, and initially set to **2 MB**.

This value applies only if the data file type is set to Continuous. Daily and per-acquisition files will contain as much data as is generated during the day or the particular acquisition.

Output Frame Type / Logging Frame Type

The frame type is one of None, APF, MBARI, **Full_ASCII**, Full_Binary, Reduced_Binary, Concentration.

If set to **None**, no frame data will be written to serial output / data log file, respectively.

For reprocessing of data, Full_ASCII or Full_Binary frames are necessary. Reduced binary and APF frames allow reprocessing for seawater deployments. APF frames only allow reprocessing of data that were collected with the integration time adjustment turned off.

Output Dark Frame / Logging Dark Frame

Dark frames output and logging is either **Output** or Suppress.

This configuration flag is provided in case when dark frames are not required or desired.

Log File Type

The data log file type is one of Acquisition, Continuous, or **Daily**.

Data log files names have a single letter (A, C, or D) followed by a 7-digit number, followed by a 3-letter extension (csv for ASCII, bin for binary data).

Acquisition based data files are started new whenever power is cycled. (But see the following setting: Acquisition File Duration.)

Continuous data log files are appended to until the Data File Size is reached. Then, the file number is incremented, and data are added to the next file.

Daily data log files contain all data that are collected within a 24 hour period. The 7-digit

SUNA Manual
For SUNA running firmware version 2.5 or later
4. Terminal Interface of the SUNA

number is made up of 4-digit for the year and 3-digits for the day-of-year (1 to 365 or 366 for leap years).

Acquisition File Duration

The Acquisition File Duration is set to 60 minutes. This setting is only used if the Log File Type is set to Acquisition.

The duration can be in the range from 0 to 1440 minutes (one full day). It specifies the time interval over which data from subsequent power-cycle events are logged to the same file.

A value of zero forces the creation of a new data log file with every power cycle, while a value of e.g., 120 collects the data from all acquisition events that occur within 120 minutes into a single file.

When using acquisition based data log files with a high frequency of acquisition events (e.g., multiple events per hour) over an extended deployment duration, the total number of files can reach tens of thousands of files. Such a number of files will slow down SUNA internal data logging.

If daily or continuous log files are not an option, the use of the acquisition file duration will ensure the number of files stays small.

DAC Minimum / Maximum Nitrate

The DAC minimum nitrate value is initially set to -5 μM , the DAC maximum nitrate value is set to 100 μM .

These values effect the output generated by the optional analog output system. See section 4.2.6 Analog Output for details.

Dat Wavelength Low / High

The data wavelength values are set to **217** and **250**.

These wavelength define the channels that are included in the APF frame.

SDI-12 Address

The SDI-12 address is factory set to the numerical value 48 (ASCII character '0').

This address is used by an SDI-12 controller when interfacing with a SUNA in SDI-12 operating mode. See section Error: Reference source not found Error: Reference source not found for details.

SUNA Manual
For SUNA running firmware version 2.5 or later
4. Terminal Interface of the SUNA

Table 12: Input / output configuration parameters

Parameter	Possible Values	Default Value	Short Name
Baud Rate	9600, 19200, 38400, 57600, 115200	57600	baudrate
Message Level	Error, Warn, Info, Debug	Info	msglevel
Message File Size [MB]	0–65	2	msgfsize
Date File Size [MB]	1–65	5	datfsize
Output Frame Type	Full_ASCII, Full_Binary, Reduced_Binary, Concentration, APF, MBARI, None	Full_ASCII	outfrtyp
Logging Frame Type		Full_ASCII	logfrtyp
Output Dark Frame	Output, Suppress	Output	outdrkfr
Logging Dark Frame	Output, Suppress	Output	logdrkfr
Log File Type	Acquisition, Continuous, Daily	Acquisition	logftype
Acquisition file duration [m]	0–1440	60	afiledur
DAC Minimum Nitrate		-5.0	dcmunno3
DAC Maximum Nitrate		100.0	dcmaxno3
Data wavelength low [nm]	210–350	217	wdat_low
Data wavelength high [nm]	210–350	250	wdat_hgh
	For the setrange command, use:		wdatboth
SDI 12 Address	48–57 (ascii characters 0–9)	48 (ascii 0)	sdi12add

Data Acquisition Configuration

Operation Mode

The operation mode is Continuous, Fixedtime, Periodic, Polled, APF, or SDI12.

In **Continuous** mode the sensor starts to acquire data as soon as initialization is complete and countdown has expired. Data acquisition proceeds, depending on the Operation Control setting, either in a sample based (1 dark sample, then Light Samples, Dark Samples, Light Samples, ...) or time based (1 dark sample, then Light Duration, Dark Duration, Light Duration) infinite cycle.

In **Fixedtime** mode, the sensor behaves as in Continuous mode, but terminates after a maximum of Fixed Time Duration seconds.

In **Periodic** mode, the sensor acquires data in regular periods, and collects data, depending on the Operation Control setting, either a fixed number of light samples (Periodic Samples) or for a fixed time (Periodic Duration).

SUNA Manual
For SUNA running firmware version 2.5 or later
4. Terminal Interface of the SUNA

In **Polled** mode, the sensor stays in low power sleep, to acquire data only after woken up by activity on the RS-232 line and then receiving a command (“Start” for indefinite or “Measure n” for a fixed number of measurements).

In **SDI-12** mode, the sensor operates as a SDI-12 device.

Operation Control

The operation control is **Duration** or Samples based.

Operation control applies to Continuous, Fixed time, and Periodic mode. Either of these operating modes is further controlled by additional parameters, and Operation Control determines which parameters apply.

Countdown

The countdown is measured in units of seconds, and initially set to **15**.

The countdown is used in Continuous and Fixedtime operation modes.

Fixed Time Duration

The fixed time duration is measured in units of seconds, and can take any positive number up to and including 1000000.

Periodic Interval

The periodic interval is restricted to a subset of values that divide the day into integer parts: 1m, 2m, 5m, 6m, 10m, 15m, 20m, 30m, **1h**, 2h, 3h, 4h, 6h, 8h, 12h, 24h.

Periodic Offset

The periodic offset is measured in seconds.

Whereas the periodic interval establishes a grid of acquisition times, the offset locates the grid relative to the start of the day (hour 0).

Note: There is a side effect when an external device needs to run prior to data acquisition.

Periodic Duration

The periodic duration is measured in seconds.

This parameter is used when **Operation Control** is set to **Duration**.

Periodic Samples

The periodic samples are measured in number of light frames.

SUNA Manual
For SUNA running firmware version 2.5 or later
4. Terminal Interface of the SUNA

This parameter is used when **Operation Control** is set to **Samples**.

Polled Timeout

The polled timeout is measured in seconds.

It determines for how long the firmware will wait for a command upon wake-up before returning to low power standby. A value of zero means there is no timeout.

APF Timeout

The APF timeout is only available in Deep SUNA sensors.

Skip Sleep At Startup

This setting is either On or **Off**.

If this setting is On, the sensor will not enter the low-power state in polled mode when first powered up. This flag allows for faster sensor response.

Lamp Stabilization Time

The lamp stabilization time is in units of 1/10 of a second.

After the lamp has ignited, a short time is required to stabilize the lamp output. Typically, lamps can be used 500 ms after being switched on. This parameter is provided to adjust the stabilization time.

Lamp Switch-Off Temperature

The lamp switch off temperature is set to 35 C. The lamp should not operate at temperatures above 35 C.

When the lamp exceeds the switch-off temperature, the sensor overrides the configured (continuous and fixedtime operation) or enforces (polled and periodic operation) a light-to-dark cycle. Upon reaching the switch-off temperature, initially five cycles of 5-light to 5-dark samples are acquired, and after those, the cycle ratio drops to 1-light to 10-dark samples. As soon as the lamp temperature has dropped below the switch-off temperature, the configured acquisition cycle resumes.

If the sensor is deployed in a warm environment, and data acquisition is only sporadic, please consult with Satlantic on ways to safely changing this configuration.

Spectrometer Integration Period

The spectrometer integration period is factory set.

The integration period should be as large as possible, to obtain a good signal; the integration period must not be so large as to cause saturation of the signal.

SUNA Manual
For SUNA running firmware version 2.5 or later
4. Terminal Interface of the SUNA

The spectrometer integration time should not be changed, because the SUNA is calibrated for the factory configured value.

Dark Averages and Light Averages

The spectrometer can perform internal averaging. Internal averaging reduces the noise of a measurement at the expense of a reduced sampling rate. However, the sampling rate is higher using internal averaging when compared to averaging the samples after separate collection.

Another advantage of internal averaging is the reduction in the amount of data generated.

Dark Samples and Light Samples

These parameters are used when **Operation Control** is set to **Samples**.

Dark and light samples are used in Continuous and Fixedtime mode, and control the lamp off/on cycle.

Dark Duration and Light Duration

These parameters are used when **Operation Control** is set to **Duration**.

Dark and light duration are used in Continuous and Fixedtime mode, and control the lamp off/on cycle.

External Device

The external device is **None** or Wiper.

If the external device is set to Wiper, power will be applied whenever a data collection begins. Thus, there will be a single wipe at the beginning of a continuous data acquisition, a single swipe at each collection event in periodic mode, or a single swipe for each collection command in polled or SDI-12 mode.

External Device Pre-run Time

The external device pre-run time can be set to a value between **0** and 200 seconds.

This is the time that the sensor waits to acquire data after applying power to the external device. The purpose of this configuration parameter is to let the external device complete its action without interfering with the sensor's measurements.

External Device On During Acquisition

The external device on during acquisition can be set to On or **Off**.

This configuration parameter allows the sensor to control if the external device is to

SUNA Manual
For SUNA running firmware version 2.5 or later
4. Terminal Interface of the SUNA

continue operating during the sensor's data acquisition.

External Device Minimum Interval

The external device minimum interval is a value between 0 and 1440 minutes (one day).

This configuration parameter limits the frequency of the operation of the external device. At each data acquisition event when the device might be run, the SUNA compares the current time against the most recent time the device was run. Only if more than the configured minimum interval has passed, the device will be operated.

SUNA Manual
For SUNA running firmware version 2.5 or later
4. Terminal Interface of the SUNA

Table 13: Data acquisition configuration parameters

Parameter	Possible Values	Default Value	Short Name
Operation Mode	Continuous, Fixedtime, Periodic, Polled, SDI12	Fixedtime	opermode
Operation Control	Duration, Samples	Samples	operctrl
Countdown [s]	0–3600	3	countdwn
Fixed Time Duration [s]	1–1000000	10	fixddura
Periodic Interval	1m, 2m, 5m, 6m, 10m, 15m, 20m, 30m, 1h, 2h, 3h, 4h, 6h, 8h, 12h, 24h	1h	perdival
Periodic Offset [s]	any value	0	perdooffs
Periodic Duration [s]	0–255	10	perddura
Periodic Samples	0–255	10	perdsmpl
Polled Timeout [s]	0–65535	10	polltout
APF Timeout [h]	0–100	10	apfatoff
Skip Sleep At Startup	On, Off	Off	skpsleep
Lamp Stabil. Time [ds]	0–255	5	stbltime
Lamp Switch-Off Temp.	*	35	lamptoff
Spectrometer Integration Period [ms]	5–60000	N/A	spintper
Dark Averages	1–200	1	drkavers
Light Averages	1–200	1	lgtavers
Dark Samples	1–65535	1	drksmpls
Light Samples	1–65535	10	lgtsmpls
Dark Duration [s]	1–65535	10	drkdurat
Light Duration [s]	1–65535	120	lgtdurat
External Device	None, Wiper	None	exdevtyp
Ex. Dev. Pre-run time [s]	0–120	0	exdevpre
Ex. Dev. During Acq.	On, Off	Off	exdevrun
Ex. Dev. Min. Interval	0–1440	60	exdival

SUNA Manual
For SUNA running firmware version 2.5 or later
4. Terminal Interface of the SUNA

Data Processing Configuration

Processing Wavelength Interval

The processing (also called fitting) interval is normally from **217** to **240 nm**.

Changing the fitting interval should be done with caution; an unsuitable fitting interval generates invalid results.

Concentrations to Fit

The number of concentrations to be used for processing is **1**, **2**, or **3**.

Freshwater calibrated sensors only use **1** concentration; saltwater calibrated sensors can be made to act like freshwater sensor by setting concentrations to fit to **1**. Normally, saltwater calibrated sensors use **3** concentrations.

Baseline Order

The baseline order is fixed to **1**.

Historically, different baseline orders were available. However, there is currently no need to change the baseline order.

Dark Correction Method

The dark correction method is one of SpecAverage or SWAverage.

The purpose of dark correction is to subtract the temperature dependent dark baseline from the measurement. When using SpecAverage, a dark spectrum is measured by either closing the shutter (of present) or switching off the lamp. Using the SWAverage works if seawater or bromide cause extinction below 200 nm, and the measurement in that wavelength range is used as a proxy for the dark baseline.

Temperature Compensation

The temperature compensation flag is On or **Off**.

Real-time processing temperature compensation only works for saltwater calibrated sensors running in APF mode. The current temperature and salinity values must be provided via the CTD command. This setting will be ignored if the sensor is not able to perform this task.

SUNA Manual
For SUNA running firmware version 2.5 or later
4. Terminal Interface of the SUNA

Salinity Fitting

The salinity fitting flag is **On** or **Off**.

Salinity fitting can only be switched off in saltwater calibrated sensors running in APF mode. The current temperature and salinity values must be provided via the CTD command. This setting will be ignored if the sensor is not able to perform this task.

Bromide Tracing

The bromide tracing flag is **On** or **Off**.

Freshwater calibrated sensors, or saltwater calibrated sensors set to operate as freshwater sensors (Concentrations to Fit set to 1) can be used to detect bromide, at an expense of the sensor's nitrate accuracy.

Absorbance Cutoff

The absorbance cutoff is a value between 0.01 and 10.0. It is normally set to **1.3**.

Whenever the absorbance of a channel exceeds the specified absorbance cutoff, that channel is excluded from processing. Setting the cutoff to the maximum value of 10.0 will guarantee that all channels will be included in processing.

Integration Time Adjustment

Integration time adjustment can be **Off**, **On**, or **Persistent**.

When set to **On** or **Persistent**, in low transmittance conditions, the sensor multiplies the normal integration time by the Integration Time Step. When the transmittance increases later on, the integration time reverts to the normal value.

When set to **Persistent**, the current Integration Time Factor is kept at power-down to be used at the next power-up event. Otherwise, the sensor starts with the normal integration time.

Integration Time Factor

The integration time factor is initially set to 1.

When integration time adjustment is **On** or **Persistent**, the integration time factor can be greater than 1. Currently, only a value of 1 or 20 is permitted.

Integration Time Step

The integration time step is set to 20. It should not be changed.

Integration Time Maximum Factor

The integration time maximum factor is set to 20. It should not be changed.

SUNA Manual
For SUNA running firmware version 2.5 or later
4. Terminal Interface of the SUNA

Table 14: Data processing configuration parameters

Parameter	Possible Values	Default Value	Short Name
Fit wavelength low [nm]	210–350	217	wfit_low
Fit wavelength high [nm]	210–350	240	wfit_hgh
	For the setrange command, use:		wdatboth
Concentrations to fit	1–3	1 or 3	fitconcs
Baseline Order	1	1	bl_order
Dark Correction Method	SpecAverage, SWAverage	SpecAverage	drkcormt
Temperature Compensation	On, Off	Off	tempcomp
Salinity Fitting	On, Off	On	salinfit
Bromide Tracing	On, Off	Off	brmtrace
Absorbance Cutoff	0.01–10.0	1.3	a_cutoff
Integration Time Adjustment	Off, On, Persistent	On	intpradj
Integration Time Factor	1–20	1	intprfac
Integration Time Step	1–20	20	intadstp
Integration Time Max	1–20	20	intadmax

The processing configuration parameters completely determine how the spectrum is processed. Some of the parameters are applicable only in some cases; non-applicable (N/A) parameters are ignored. TS correction processing, even if configured, will only proceed if temperature and salinity values have been provided via the APF CTD command. The following table gives the valid parameter combinations.

Table 15: Combinations of data processing configuration parameters

Processing Mode	Fit Con.	Br Trace	TS Cmp.	Sal. Fit.	Comment
Freshwater	1	Off	N/A	N/A	
Freshwater and bromide trace	1	On	N/A	N/A	
Fit 3 species	3	N/A	Off	N/A	Non-T-S correcting processing
T correction (fit S)	3	N/A	On	On	If T unavailable, uses Fit 3 species
TS correction	3	N/A	On	Off	If TS unavailable, uses Fit 3 species

SUNA Manual
For SUNA running firmware version 2.5 or later
4. Terminal Interface of the SUNA

4.2.4 Polled Mode Commands

Polled mode is useful when the sensor is externally controlled. The sensor waits in low power standby for activity on its input line, and after initialization confirms its readiness to respond to commands via the CMD? prompt. The polled mode timeout setting controls for how long the sensor stays at the polled mode prompt before returning to low power standby.

Polled mode commands are:

Start	begin continuous data acquisition, terminate by sending the \$ character
Measure N	take N light data frames (if N is zero, take a single dark data frame)
Timed N	take light data frames for a duration of N seconds
CTD	send CTD data for temperature-salinity correction (sensor must be able to perform temperature-salinity correction, and processing must be configured for it)
Status	print a sensor status message SATMSG,SUNA,S/N,LampTime,Humidity,Voltage,LampTemp,SpecTemp
\$	enter command line
Sleep	enter low power standby

4.2.5 SDI-12 Mode Commands

The SUNA supports all basic SDI-12 commands, as required by Version 1.3 of the SDI-12 Specification. The commands and the SUNA response are described below. In these descriptions, 'a' refers to the SUNA's SDI-12 address, <CRC> refers to the 3-character Cyclic Redundancy Check Sum, <CR> indicates a carriage return character, and <LF> indicates a line feed character. The SUNA's address defaults to 0 but is configurable by the user. For commands not supported or explicitly described below, the SUNA responds per the SDI-12 v1.3 specification. Details of the command protocol are beyond the scope of this document. Interested users should refer to the SDI-12 specification.

SDI-12 operation has been tested using the SDI-12 Verifier from NR Systems Inc (<http://www.sdi-12-verifier.com>).

In SDI-12 operation, internal data logging can be used to collect full spectral data. Data can then be retrieved after deployment for further analysis or data reprocessing. If a wiper is integrated, SDI-12 measurement commands will cause the wiper to sweep before each measurement, adding to the time it takes to perform a measurement.

Command: Acknowledge Active (a!)

Response: a<CR><LF>

Notes: confirms SUNA SDI-12 address

SUNA Manual
For SUNA running firmware version 2.5 or later
4. Terminal Interface of the SUNA

Command: Send Identification (a!)

Response: allccccccmmmmmmvvvxxxxxxxxxxxxx<CR><LF>

Notes:

- a SUNA address
- ll 2 character SDI-12 version, e.g. 13 for version 1.3
- ccccccc 8 character Vendor identification, in this case SATLANTC
- mmmmmm 6 character sensor model, in this case SUNA
- vvv 3 character sensor version, e.g. v2
- xxxxxxxxxxxxx up to 13 character optional field, here used for firmware version.
Format: F<MAJOR>.<MINOR>.<PATCH>
If the SUNA determines that the firmware information will not fit in the allocated space, it will not output this field.

An example response is 013SATLANTC SUNA v2 0002F2.1.2<CR><LF>

Command: Change Address (aAb!)

Response: b<CR><LF>

Notes: SUNA responds with its new SDI-12 address: b

Command: Address Query (?!)

Response: a<CR><LF>

Notes: SUNA responds with its SDI-12 address: a

Command: Verify (V!)

Response: atttn<CR><LF>

Notes: SUNA always responds with a0000<CR><LF>
No SDI-12 diagnostic information is supported.

Command: Measurement (aM!)
Measurement and CRC (aMC!)
Concurrent Measurements (aC!)
Concurrent Measurements and CRC (aCC!)

Response: atttn<CR><LF> (measurement)
atttnn<CR><LF> (concurrent measurement)

Notes:

ttt the time, in seconds, until the sensor will have a measurement ready. The SUNA normally responds within less than 30 seconds.

SUNA Manual
For SUNA running firmware version 2.5 or later
4. Terminal Interface of the SUNA

n or nn the number of measurement values the SUNA will return in one or more subsequent send data commands. For the SUNA, this value is 4.

For example: 00104<CR><LF> (measurement)
001004<CR><LF> (concurrent measurement)

The SUNA reports 10 seconds are required to make the measurements. Generally it will complete sooner and issue a service request to the controller.

In subsequent data commands, the four values returned will be:

- nitrate concentration [μ M]
- nitrogen in nitrate concentration [mg/l]
- light spectrum average
- dark spectrum average

**Commands: Additional Measurements (aM1!)
Additional Measurements and CRC (aMC1!)
Additional Concurrent Measurements (aC1!)
Additional Concurrent Measurements and CRC (aCC1!)**

Response: atttn<CR><LF> (measurement)
attnn<CR><LF> (concurrent measurement)

Notes:

ttn the time, in seconds, until the sensor will have a measurement ready.
The SUNA normally responds with 4 seconds

n or nn the number of measurement values the SUNA will return in one or more subsequent send data commands. For the SUNA, this value is 7.

For example: 00047<CR><LF> (measurement)
000407<CR><LF> (concurrent measurement)

In subsequent data commands, the seven values returned will be:

- lamp temperature [C]
- spectrometer temperature [C]
- lamp time [s]
- relative humidity [%]
- internal voltage [V]
- regulated voltage [V]
- supply voltage [V]

SUNA Manual
For SUNA running firmware version 2.5 or later
4. Terminal Interface of the SUNA

**Commands: Additional Measurements (aM2!),
Additional Measurements and CRC (aMC2!),
Additional Concurrent Measurements (aC2!),
Additional Concurrent Measurements and CRC (aCC2!),**

Response: atttn<CR><LF> (measurement)
atttnn<CR><LF> (concurrent measurement)

Notes:

ttn the time, in seconds, until the sensor will have a measurement ready.
The SUNA normally responds with 4 seconds

n or nn the number of measurement values the SUNA will return in one or more
subsequent send data commands. For the SUNA, this value is 7.

For example: 00109<CR><LF> (measurement)
001013<CR><LF> (concurrent measurement)

In subsequent data commands, the 9 (or 13 for concurrent measurements) values
returned will be:

- nitrate concentration [μ M]
- nitrogen in nitrate concentration [mg/l]
- light spectrum average
- dark spectrum average
- measurement date
- measurement time
- absorbance at 254 nm
- absorbance at 350 nm
- bromide trace
- lamp temperature [C] (concurrent measurement only)
- spectrometer temp. [C] (concurrent measurement only)
- relative humidity [%] (concurrent measurement only)
- rmse of nitrate processing (concurrent measurement only)

**Command: Additional Measurements (aM3! - aM9!),
Additional Measurements and CRC (aMC3! - aMC9!),
Additional Concurrent Measurements (aC3! - aC9!),
Additional Concurrent Measurements and CRC (aCC3! - aCC9!)**

Response: atttn<CR><LF> (measurement)
atttnn<CR><LF> (concurrent measurement)

Notes: The SUNA supports only 2 additional measurements.
ttn is always 000.
n is always 0.
nn is always 00.

SUNA Manual
For SUNA running firmware version 2.5 or later
4. Terminal Interface of the SUNA

Command: Send Data (aD0! - aD9!)

Response: a<values><CR><LF>
or a<values><CRC><CR><LF>

Notes: Sends group of data to the controller after a measurement or verification command. The response will vary depending on the previous measurement command.

After the M! or C! command, the SUNA will respond with the 4 above listed values (nitrate concentration in two units, light and dark spectrum average).

For example: 0+1039.040+14.8434+22799+671<CR><LF>

After the MC! or CC! command, the SUNA will respond as per the M! or C! command, but with a CRC value attached.

For example: 0+1038.452+14.8350+22683+672NtW<CR><LF>

After the M1! command, the SUNA will respond to the aD0! command with the first 4 values that are listed above (two temperatures, lamp time and humidity).

For example: 0+33.188+23.500+3315+23.2<CR><LF>

The SUNA will then respond to the aD1! Command with the remaining 3 values (three voltages).

For example: 0+11.92+5.43+13.68<CR><LF>

After the MC1! command, the SUNA will respond as per the M1! command, but with a CRC value attached.

For example: 0+33.813+23.500+3356+23.2AsF<CR><LF>, followed by 0+11.92+5.43+13.62EyF<CR><LF>

The response to the aC1!, aCC1!, aM2!, aMC2!, aC2!, aCC2! commands follows an analogous pattern.

**Command: Continuous Measurements (aR0! - aR9!),
Continuous Measurements and Request CRC (aRC0! - aRC9!)**

Response: a<values><CR><LF>

Notes: Continuous measurements are not supported by the SUNA in SDI-12 mode due to limited lamp life time. The SUNA will always report a0<CR><LF> or a0<CRC><CR><LF>.

4.2.6 Analog Output

The SUNA can work with analog input data acquisition systems, such as a Sea-Bird CTD profiler, by using the optional analog output system. The analog interface allows

SUNA Manual
For SUNA running firmware version 2.5 or later
4. Terminal Interface of the SUNA

merging of nitrate data with other data recorded at the same time. A standard application is to integrate the voltage signal into a CTD profiler's auxiliary port, providing a profile of conductivity, temperature, and nitrate versus depth.

Generating Voltage and Current for a Nitrate Concentration

The SUNA generates analog voltage and current representations of the calculated nitrate values. The voltage is generated using a precision 12-bit digital-to-analog converter (DAC) and is in the range of 0.095 to 4.095 Volts. The current is generated using a precision 16-bit DAC and is in the range of 4 to 20 mA.

The SUNA has two configuration values, DAC Minimum Nitrate and DAC Maximum Nitrate, that correspond to the lower and upper bounds of the voltage and current output. If the nitrate concentration is below the DAC Minimum, the output voltage and current will be the minimum voltage or current. If the nitrate concentration is above the DAC Maximum, the output voltage and current will be the maximum voltage or current.

Otherwise, the voltage and current are calculated via

$$V = V_{min} + \frac{V_{max} - V_{min}}{DAC_{max} - DAC_{min}} \cdot (C_{nitrate} - DAC_{min}) \quad \text{and}$$

$$I = I_{min} + \frac{I_{max} - I_{min}}{DAC_{max} - DAC_{min}} \cdot (C_{nitrate} - DAC_{min}) \quad ,$$

where

- $C_{nitrate}$ is the nitrate concentrations
- DAC_{min} is the nitrate concentration at minimum voltage and current
- DAC_{max} is the nitrate concentration at maximum voltage and current
- V is the generated voltage
- V_{min} is 0.095 V, the minimum voltage
- V_{max} is 4.095 V, the maximum voltage
- I is the generated current
- I_{min} is 4 mA, the minimum current
- I_{max} is 20 mA, the maximum current

The actual voltage or current may differ slightly from the theoretical values. See below on how to accurately calibrate the analog output system.

Calculating Nitrate Concentration from Voltage and Current

The inverse voltage and current equations are

SUNA Manual
For SUNA running firmware version 2.5 or later
4. Terminal Interface of the SUNA

$$C_{nirate} = DAC_{min} + \frac{DAC_{max} - DAC_{min}}{V_{max} - V_{min}} \cdot (V - V_{min}) \quad \text{and}$$

$$C_{nirate} = DAC_{min} + \frac{DAC_{max} - DAC_{min}}{I_{max} - I_{min}} \cdot (I - I_{min}) \quad ,$$

using the same symbols as above.

These equation can be written more compact as

$$C_{nirate} = A_0 + A_1 \cdot V \quad \text{and}$$

$$C_{nirate} = B_0 + B_1 \cdot I \quad ,$$

where

$$A_1 = \frac{DAC_{max} - DAC_{min}}{V_{max} - V_{min}} \quad \text{is the voltage scale coefficient}$$

$$A_0 = DAC_{min} - A_1 \cdot V_{min} \quad \text{is the voltage offset coefficient}$$

$$B_1 = \frac{DAC_{max} - DAC_{min}}{I_{max} - I_{min}} \quad \text{is the current scale coefficient}$$

$$B_0 = DAC_{min} - B_1 \cdot I_{min} \quad \text{is the current offset coefficient}$$

In-System Calibration

The above defined scale and offset coefficients are based on the nominal minimum and maximum voltage and current values. In a deployed system, voltage and current may differ, due to transmission losses. Ideally, the true low and high voltage or current values are used instead of the nominal values.

In order to perform an in-system calibration, a Y-cable is required, that connects the SUNA to both the data acquisition device and a computer. Please contact Satlantic for assistance in creating or purchasing such a cable. With this cable in place, the SUNA is tasked to generate the low DAC and then the high DAC output. The low and high voltage or current values are measured in the data acquisition device, and used to calculate the in-system scale and offset coefficients:

$$A_1 = \frac{DAC_{max} - DAC_{min}}{V_{high} - V_{low}} \quad \text{is the in-system calibrated voltage scale coefficient}$$

$$A_0 = DAC_{min} - A_1 \cdot V_{low} \quad \text{is the in-system calibrated voltage offset coefficient}$$

$$B_1 = \frac{DAC_{max} - DAC_{min}}{I_{high} - I_{low}} \quad \text{is the in-system calibrated current scale coefficient}$$

SUNA Manual
For SUNA running firmware version 2.5 or later
4. Terminal Interface of the SUNA

$B_0 = DAC_{min} - B_1 \cdot I_{low}$ is the in-system calibrated current offset coefficient

The SUNA can be tasked to generate the low and high analog output via SUNACom (see the SUNACom user manual) or using the `DAC Low` and `DAC High` commands in the terminal interface (see section 4.2.1 Status and Maintenance Commands).

SUNA Manual
For SUNA running firmware version 2.5 or later
5. Configuration Parameters in Context

5. Configuration Parameters in Context

While section 4.2.3 Configuration Commands gives a complete list configuration parameters, this section describes groups of configuration parameters that are related because they are used alongside each other.

Configuration parameters are discussed in four categories: Build, Input/Output, Data Acquisition, Data Processing.

5.1 Build Configuration

Build configuration parameters describe the hardware of the sensor, and determine which capabilities are available. Build parameters limit the values some other configuration parameters can take. Only some combinations of build parameters are supported.

Sensor Identification:

Sensor Type	SUNA
Sensor Version	V2
Sensor Serial Number	0000–9999

Table 16: SUNA build variants

Option	Description
Super capacitors	Provides short-term power in case when power is lost
PCB supervisor	Provides low-power sleep state
Relay	Allows the SUNA to disconnect itself from its power supply
Analog output	Generates a voltage or current representation of the nitrate values
SDI-12	Allows the SUNA to operate as a SDI-12 client
USB	Allows interfacing via USB, higher data rates than via serial communication
Internal logging	Permits the SUNA to operate as its own data logger
Scheduling	Permits the SUNA to autonomously schedule its data acquisition
APF Mode & T-S Correction	Provides the interface protocol used in APEX floats, and supports on-board temperature-salinity correction of nitrate values

SUNA Manual
For SUNA running firmware version 2.5 or later
5. Configuration Parameters in Context

5.2 Input / Output Configuration

Input to the SUNA is via serial RS-232 or if available, via USB, or in SDI-12 mode, via the SDI-12 port.

Output of the sensor is sent via serial RS-232. If available and connected, output is sent via UBS. Data can also be logged internally to file, or converted to an analog voltage or current for output.

With the exception of SDI-12 mode, output generation is independent of the operation mode (see next section), and multiple output destinations can be served concurrently.

Baud Rate	The RS-232 data rate.
Message Level	Error, Warning, Info, Debug, Trace
Message File Size	0–65 [MB]

The sensor generates log messages. The selected message level determines the amount of logging: the least messages are generated for the Error message level, and the most are generated for the Trace message level. Messages are always sent to RS-232, and logged internally if the sensor is equipped with internal logging. Internal logging of messages can be switched off by setting the message file size to zero.

Output Frame Type	Full_ASCII, Full_Binary, Reduced_Binary, Concentration, APF, MBARI, None
Logging Frame Type	Full_ASCII, Full_Binary, Reduced_Binary, Concentration, APF, MBARI, None
Output Dark Frames	Suppress, Output
Logging Dark Frames	Suppress, Output
Logging File Type	Acquisition, Continuous, Daily
Data File Size	1–99 [MB]

Digital output of data is in the form of fixed or variable length strings of bytes (see section 7. SUNA Frame Definitions). If output or internal logging of frames is not desired, the frame type is set to None. Omitting frame generation, output, and logging when not needed increases the data rate of the sensor.

Dark data frames may be useful for monitoring sensor performance, but are not needed for regular data acquisition. When acquisition time and/or transfer speed or volume are an issue, dark frame output and logging can be suppressed.

Internal data log files are generated with an automated naming schema. Files may be per Acquisition (a new file with each power-up), or Daily (all data collected at one day are placed into a single file), or Continuous (a new file is started when the current file reaches a configured size).

The data log file type should be chosen to match the planned data acquisition and the intended method of data utilization.

For moored deployments, either in periodic mode or scheduled by a controller, daily

SUNA Manual
For SUNA running firmware version 2.5 or later
5. Configuration Parameters in Context

data log files are a good choice: The number of files generated over a number of months is modest, while it is easy to select data for a range of dates. If per-acquisition data log files were used instead, many thousand files could be generated. While a SUNA can manage such a number of files, it may become slower. Generally, managing thousands of files can be cumbersome.

For profiles, which are typically collected in continuous operation, per acquisition data log files are a convenient choice: All data between power up and power down will be placed into the same file, facilitating subsequent data management. Using daily or continuous data log files when acquiring multiple profiles can split a profile into two files, requiring manual realignment.

Continuous data log files in conjunction with the maximum data log file size offer control over the number of files and the size of the files that will be generated.

When logging data on board the SUNA, care should be taken to ensure there is sufficient space on the file system. Ideally, data are off-loaded from the SUNA prior to deployment, and the file system cleared as much as possible. When the on board file system is full, subsequent data can no longer be logged and will be lost.

DAC Minimum Nitrate concentration representing minimum analog output.
 DAC Maximum Nitrate concentration representing maximum analog output.

SDI-12 Address The address used by the sensor in SDI-12 mode. It is a number from 48 to 57, corresponding to ASCII values '0' to '9'.

5.3 Data Acquisition Configuration

Data acquisition is primarily controlled via the operating mode. Each operating mode has secondary configuration parameters for fine tuning. Both data processing and output generation configuration are independent of the data acquisition scheme. The exception is SDI-12 mode, which has its own output interface.

In the following paragraphs, each operating mode is described, and the configuration parameters relevant to that operating mode are explained.

5.3.1 Continuous and Fixed-time Operating Mode

Continuous mode generates an uninterrupted stream of data. Data collection is autonomous.

When powered, the sensor starts collecting and outputting data. Data acquisition ends when power is removed or the \$ character is sent via serial input. In fixed time mode, data acquisition proceeds for the maximum time configured via fixed-time duration, after which the sensor enters low-power standby.

When collecting data in continuous mode, changes in the spectrometer temperature impact the measured concentrations. For best accuracy, regular dark measurements are required to compensate for the changing temperature. The user can choose a dark

SUNA Manual
For SUNA running firmware version 2.5 or later
5. Configuration Parameters in Context

to light data rate based either of a number of samples or on the duration, via the Operation Control configuration parameter. Then, the sensor will collect data in a D-L-...-L-D-...-D-L... schema. If operation control is SAMPLES based, the user controls the respective numbers via the Light Samples and Dark Samples configuration parameters. When operation control is DURATION based, the user controls the respective durations via the Light Duration and Dark Duration configuration parameters.

Configuration: Operation Control, Countdown, Light Samples, Dark Samples, Light Duration, Dark Duration.

5.3.2 Periodic Operating Mode

Periodic mode generates short bursts of data at pre-configured times. Data collection is autonomous.

When powered, the sensor enters low-power standby. Any activity on RS-232 or USB brings the sensor within three seconds to the command interface, indicated by SUNA>. After a duration of Countdown seconds (configuration parameter) without input, the sensor returns to low power standby.

At the pre-configured times, the sensor collects a fixed number of data points, or data points for a fixed duration. After data collection, the sensor returns to low-power standby.

The start times of the data collection events are separated by a fixed interval. Possible values for the interval are 1, 2, 5, 10, 12, 15, 30, minutes, or 1, 2, 3, 4, 6, 12, or 24 hours. The time grid starts relative to the start of the day. The time grid can be offset from the start of the day via the Periodic Offset configuration parameter.

The data collection event can be either sample or duration based. This is controlled via the Operation Control configuration parameter. For sample based data collection, the Periodic Duration configuration parameter determines the number of data samples that will be collected. For duration based data collection, the Periodic Duration configuration parameter determines the number of seconds over which data will be collected.

Configuration: Operation Control, Periodic Interval, Periodic Offset, Periodic Duration, Periodic Samples, Countdown

5.3.3 Polled Operating Mode

Polled mode generates data in response to a command. Data collection is driven by a controller via the serial interface.

When powered, the sensor enters a low power standby. Any activity on RS-232 or USB brings the sensor within three seconds to the polled command prompt, indicated by CMD?. After a duration of Polled Timeout (configuration parameter, in seconds) without command input, the sensor returns to low power standby.

Supported commands are described in section 4.2.4 Polled Mode Commands.

SUNA Manual
For SUNA running firmware version 2.5 or later
5. Configuration Parameters in Context

Configuration: Polled timeout, Skip Sleep

5.3.4 SDI-12 Operating Mode

SDI-12 mode generates data in response to a command. Data collection is SDI-12 controller driven. When powered, the sensor enters a standby state where it responds only to SDI-12 commands. The sensor interface conforms to the SDI-12 protocol. Sending a \$ character via the RS-232 port gives access to the command prompt. Supported commands are described in section 4.2.5 SDI-12 Mode Commands.

Configuration: SDI-12 Address

Table 17: Data acquisition configuration parameters by operating mode.

Name	Acceptable Values	Explaining Subsection
Operation mode	Continuous, Fixedtime, Periodic, Polled, SDI12	
Operation control	Samples, Duration	Continuous mode, Periodic mode
Fixed time duration	1–1000000	Continuous mode
Light samples	1–65535	Continuous mode
Dark samples	1–65535	Continuous mode
Light duration	1–65535	Continuous mode
Dark duration	1–65535	Continuous mode
Periodic interval	1m, 2m, 5m, 6m, 10m, 15m, 20m, 30m, 1h, 2h, 3h, 4h, 6h, 8h, 12h, 24h	Periodic mode
Periodic offset	0–86399	Periodic mode
Periodic samples	1–255	Periodic mode
Periodic duration	1–255	Periodic mode
Polled timeout	0–65535	Polled mode
APF timeout	1–100	APF mode
Skip Sleep at Start	On, Off	Polled mode, APF mode

SUNA Manual
For SUNA running firmware version 2.5 or later
5. Configuration Parameters in Context

5.4 Data Processing Configuration

Data processing is independent of input/output and data acquisition configuration.

5.4.1 Basic Data Processing

Data processing normally uses the 217 to 240 nm interval of the measured spectrum. The measured absorbance in that interval is decomposed into absorbances due to individual absorbers, and the absorbance due to an absorber is converted to a concentration value for that absorber.

The sensor can decompose the absorbance either solely into nitrate (freshwater use) or, if calibrated for this, into nitrate, seawater, and seawater temperature effects (oceanographic use). If a sensor has been calibrated for oceanographic use, but is to be used in a freshwater environment where the salinity will be below 1 PSU, the user should constrain data processing to use only nitrate decomposition by setting the Concentrations-to-Fit configuration parameter from 3 to 1. Reducing the number of concentrations to fit improves the precision of the processed data.

Under normal conditions, no other processing parameters need to be changed.

Configuration: Concentrations to Fit, Fit Wavelength Low, Fit Wavelength High

5.4.2 Special Case: Bromide Tracing

In freshwater, bromide can be used as a tracer. If the sensor's Bromide Trace configuration parameter is set to On, the sensor will analyze the measured spectrum for the presence of bromide, and output the result in its regular frame.

Configuration: Bromide Tracing

5.4.3 Special Case: Highly Absorbing Water

Highly absorbing waters pose a challenge to the sensor. In its normal configuration, the part of the spectrum with an absorbance of more than 1.3 is excluded from processing. Using parts of the spectrum of higher absorbance will reduce accuracy and precision of the measured concentrations. The user may increase the Absorbance Cutoff to a higher value, to extend the operational range of the sensor at the expense of reduced data quality.

If the absorbance reaches values between 2.0 and 2.5, data quality deteriorates further. If the Integration Time Adjustment configuration parameter is set to On or Persistent, the sensor will start making measurement using a spectrometer integration time that is 20 times as long as the normal integration time. This longer integration time increases the signal-to-noise ratio in faint light conditions, and allows the sensor to operate in optically dense conditions. When the optical density drops, the sensor will revert to the normal spectrometer integration time.

SUNA Manual
For SUNA running firmware version 2.5 or later
5. Configuration Parameters in Context

Configuration: Absorbance Cutoff, Integration Time Adjustment, Integration Time Factor, Integration Time Step, Integration Time Maximum Factor.

Table 18: Data processing configuration parameters in use case context

Name	Acceptable Values	Subsection for Explanation
Lower limit of fit interval	217–350	Basic processing
Upper limit of fit interval	217–350	Basic processing
Concentrations to fit	1–3	Basic processing
Temperature correction	On, Off	Temperature-Salinity Correction
Salinity fitting	On, Off	Temperature-Salinity Correction
Bromide tracing	On, Off	Bromide Tracing
Absorbance cutoff	0.01–10.0	Highly Absorbing Water
Integration Time Adjustment	Off, On, Persistent	Highly Absorbing Water
Integration Time Factor	1–20	Highly Absorbing Water
Integration Time Step	1–20	Highly Absorbing Water
Integration Time Maximum	1–20	Highly Absorbing Water

SUNA Manual
For SUNA running firmware version 2.5 or later
6. Use Scenarios

6. Use Scenarios

6.1 Profiling

6.1.1 Objectives and Considerations

A profile is a continuous series of measurements taken over a depth range, where nitrate concentrations may be collected for either down and up cast or both. The descent and ascent rate together with the sensor's data rate determine the spatial resolution of the profile.

The data rate depends on a number of factors. The integration period of the spectrometer sets a lower limit on the data rate. Additional time is required for data processing and data output. Output, even at high baud rates, is always slower than internal logging of data.

6.1.2 Example

This example assumes that the sensor is not outputting any data, but only logging data internally. The ascend and/or descend rates of the profiler are assumed to be rather modest, thus internal averaging of spectra is used to obtain improved data quality.

It is further assumed that temperature and salinity data are collected alongside the sensor, for post-processing employing temperature-salinity correction. Therefore, full spectral data are logged.

SUNA Manual
For SUNA running firmware version 2.5 or later
6. Use Scenarios

	Setting Parameter	Value in Profiling Deployment
Input / Output	Message Level	Warn
	Message File Size	2
	Output Frame	None.
	Logging Frame	Full_ASCII
	Logging Dark Frame	Output
	Log File Type	Acquisition
Data Acquisition	Operation Mode	Continuous
	Operation Control	Samples
	External Device	None
	Countdown	15
	Dark Averages	1
	Light Averages	5
	Dark Samples	1
	Light Samples	60
Process	Temperature Compensation	Off
	Salinity Fitting	On
	Bromide Tracing	Off
	Concentrations to fit	3
	Dark Correction Method	SpecAverage
	Absorbance Cutoff	1.3
	Integration Time Adjustment	On
	Fit Wavelength Low / High	217, 240

Table 19: Configuration parameters illustrating a profiling deployment.

6.2 Moored

6.2.1 Objectives and Considerations

In moored applications, power management, especially if running from battery, has to be considered.

Moored applications typically have infrequent service intervals. As most environments cause bio-fouling of the sensor, either passive (fouling guard) or active (wiper) counter-

SUNA Manual
For SUNA running firmware version 2.5 or later
6. Use Scenarios

measures are necessary.

The sensor can run autonomously (periodic mode), respond to a controller (polled, APF, or SDI-12 mode), or be powered up and down by a controller (running in continuous mode).

Regardless of the operation control, moored applications often collect discrete samples. The user can choose to either collect a series of samples, and perform averaging as a second data processing step. Alternatively, the sensor can be configured to collect a single data sample that already is an average of multiple measurements.

Before the deployment, the sensor must receive a reference spectrum update, where the reference spectrum is collected under data acquisition conditions that resemble the deployment data collection conditions.

6.2.2 Example

This example assumes that the SUNA operates autonomously in periodic operating mode. Data are collected in analog form by a data acquisition device, and also logged internally for post-deployment analysis.

The SUNA is also equipped with a wiper, that is internally controlled. It takes the wiper some 15 seconds to complete a sweep through the sampling volume. The wiper speed is highest for an unobstructed sampling volume, and when operating at the upper input voltage range. The minimum required delay between subsequent wipes is 30 seconds.

SUNA Manual
For SUNA running firmware version 2.5 or later
6. Use Scenarios

	Setting Parameter	Value in Moored Deployment
Input / Output	Message Level	Info
	Message File Size	2
	Output Frame	None.
	Logging Frame	Full_ASCII or Full_Binary
	Logging Dark Frame	Output
	Log File Type	Acquisition
Data Acquisition	Operation Mode	Periodic
	Operation Control	Samples
	External Device	Wiper
	External Pre-Run Time	15
	Periodic Interval	15m
	Periodic Samples	10
	Dark Averages	1
	Light Averages	1
Process	Temperature Compensation	Off
	Salinity Fitting	On
	Bromide Tracing	Off
	Concentrations to fit	3
	Dark Correction Method	SpecAverage
	Absorbance Cutoff	1.3
	Integration Time Adjustment	On
	Fit Wavelength Low / High	217, 240

Table 20: Configuration parameters illustrating a moored deployment.

SUNA Manual
For SUNA running firmware version 2.5 or later
7. SUNA Frame Definitions

7. SUNA Frame Definitions

7.1 Frames with Synchronization Headers

The frames described in this section start with a ten character header which uniquely identifies the sensor and data type. The unique header allows to extract sensor specific frames from arbitrary collections of data.

There are two types of such frames: Variable length frames and fixed length frames. In variable length frames, the fields are in ASCII format and comma separated . In fixed length frames, each field has a fixed size, and is usually in binary format.

The variable length frame headers start with SAT, followed by three characters identifying the frame type. SATSLF and SATSDF for full ASCII light and dark frames, and SATSLC and SATSDC for concentration light and dark frames, respectively. The last four characters are the sensor serial number. Example for serial number 1234: SATSLC1234 for concentration light frame.

The fixed length frame headers start with SAT, followed by three characters identifying the frame type: SATSLB and SATSDB for full binary light and dark frames, and SATSLR and SATSDR for reduced binary and dark frames, respectively. The last four characters are the sensor serial number. Example for serial number 1234: SATSLR1234 for reduced binary light frame.

For each field in these frames, format and size are given. The formats are ASCII Integer (AI), ASCII Float (AF), ASCII String (AS), Binary Unsigned Integer (BU), Binary Float (BF), and Binary Double (BD). Binary fields have fixed sizes, ASCII fields may have fixed or variable sizes. BF and BD data formats conform to the IEEE 754 standard. Binary data are in big endian order.

SUNA Manual
For SUNA running firmware version 2.5 or later
7. SUNA Frame Definitions

Table 21: Synchronization header frame definitions

<i>Field</i>	<i>Concentration</i>	<i>Full ASCII</i>	<i>Full Binary</i>	<i>Reduced Binary</i>
Header and Serial Number	SATSLCnnnn SATSDCnnnn	SATSLFnnnn SATSDFnnnn	SATSLBnnnn SATSDBnnnn	SATSLRnnnn SATSDRnnnn
Date, year and day-of-year	AI 7	AI 7	BS 4	BS 4
Time, hours of day	AF	AF	BD 8	BD 8
Nitrate concentration [μ M]	AF	AF	BF 4	BF 4
Nitrogen in nitrate [mg/l]	AF	AF	BF 4	BF 4
Absorbance at 254 nm	AF	AF	BF 4	BF 4
Absorbance at 350 nm	AF	AF	BF 4	BF 4
Bromide trace [mg/l]	AF	AF	BF 4	BF 4
Spectrum average	-	AI	BU 2	BU 2
Dark value used for fit	-	AI	BU 2	BU 2
Integration time factor	-	AI	BU 1	BU 1
Spectrum channels	-	256 x AI	256 x BU 2	32 x BU 2
Internal temperature [$^{\circ}$ C]	-	AF	BF 4	-
Spectrometer temperature [$^{\circ}$ C]	-	AF	BF 4	BF 4
Lamp temperature [$^{\circ}$ C]	-	AF	BF 4	BF 4
Cumulative lamp on-time [s]	-	AI	BU 4	-
Relative Humidity [%]	-	AF	BF 4	BF 4
Main Voltage [V]	-	AF	BF 4	-
Lamp Voltage [V]	-	AF	BF 4	-
Internal Voltage [V]	-	AF	BF 4	-
Main Current [mA]	-	AF	BF 4	-
Fit Aux 1	-	AF	BF 4	-
Fit Aux 2	-	AF	BF 4	-
Fit Base 1	-	AF	BF 4	-
Fit Base 2	-	AF	BF 4	-
Fit RMSE	AF	AF	BF 4	BF 4
CTD Time [seconds since 1970]	-	AI	BU 4	BU 4
CTD Salinity [PSU]	-	AF	BF 4	BF 4
CTD Temperature [$^{\circ}$ C]	-	AF	BF 4	BF 4
CTD Pressure [dBar]	-	AF	BF 4	BF 4
Check Sum	-	AI	BU 1	BU 1
Terminator	CR LF	CR LF	-	-

7.2 APF Frame

SUNA Manual
For SUNA running firmware version 2.5 or later
7. SUNA Frame Definitions

Fields in the APF frame are comma separated.

Table 22: APF data frame definition

Frame Field	Example Value
Record 16-bit CRC	0xE0B6
Record Data Type	A
Timestamp (GMT)	7/22/2011 19:04
CTD Timestamp (1970 epoch seconds)	0
CTD Pressure (dBar)	-1
CTD Temperature [°C]	-1
CTD Salinity	-1
Sample Counter	246
Power Cycle Counter	3
Error Counter	1
Internal Temperature [°C]	27.34
Spectrometer Temperature [°C]	28.12
Internal Relative Humidity (%)	4.21
Supply Voltage (V)	11.78
Supply Current (A)	0.523
Reference Detector Mean	2345
Reference Detector Standard Deviation	6.54
Dark Spectrum Mean	567
Dark Spectrum Standard Deviation	7.23
Sensor Salinity	32.23
Sensor Nitrate	12.21
Absorbance Fit Residuals (RMS)	1.23E-04
Output Pixel Begin	33
Output Pixel End	63
Output Spectrum (Hex Packed, 4 characters for each output channel, Begin-End+1 channels)	0701079D085B092009F90ADC0BDD0CFC0E370F88110512A41470165D187A1AAA1...
Seawater Dark (Mean of Channels 1 to 5)	591.2

SUNA Manual
For SUNA running firmware version 2.5 or later
7. SUNA Frame Definitions

7.3 MBARI Frame

MBARI frames are generated for dark and for light spectrum measurements. Dark frames begin with a D, light frames begin with an S. All fields in the MBARI frame are comma separated.

Table 23: MBARI data frame definition

Frame Field	Example Value
Frame Type for dark frame, or for light (spectrum) frame	D S
Timestamp (GMT)	7/22/2011 19:04:23.1234
Internal Temperature [°C]	27.34
Spectrum Average for dark frame, or Reference Detector Average for light frame	2345.23
Spectrum Standard Deviation for dark frame, or Reference Detector Std. Dev. for light frame	6.54
Output Spectrum (256 channels)	12345
Terminator	CR LF

SUNA Manual
For SUNA running firmware version 2.5 or later
8. SUNA Calibration File

8. SUNA Calibration File

8.1 File Name

SUNA calibration files use the following file naming convention: The file name has a base of eight letters and a three letter 'CAL' extension. The file name is not case sensitive. The first three letters are 'SNA', followed by the four digits of the sensor serial number, and the last letter is a version letter. Version letters run from A to Z.

8.2 File Format

SUNA calibration files are text files, consisting of a series of header lines followed by a series of coefficient lines. A line is terminated by either a line feed character (hexadecimal 0A) or by a carriage return character followed by a line feed character (hexadecimal 0D 0A).

A header line always begins with the 'H,' character sequence, followed by auxiliary information. A coefficient line always begins with the 'E,' character sequence, followed by a series of comma separated floating point numbers.

The last line may be succeeded by a series of CTRL-Z (hexadecimal 1A) padding characters. These are introduced by the XMODEM protocol that is used to transfer calibration files from and to the SUNA, and must be ignored.

8.3 File Interpretation

The first header line always contains the sensor type (SUNA) and the sensor four digit serial number, followed by some generic comments. Subsequent header lines contain information about the generation.

If there is a header line with the keyword T_S_CORRECTABLE, the coefficients can be used for temperature salinity correction.

The temperature of the calibration is given in the T_CAL header line. This temperature is needed when applying the temperature salinity correction.

The last header line always consists of a comma separated list of labels. These labels describe the content of the coefficient lines. The number of labels in this line must match the number of entries in the coefficient lines. The first label is always Wavelength, the second label is normally NO3, and the last label is always Reference. For sensors calibrated for sea water, there are a SWA and a TSWA label between the NO3 and the Reference label.

Calibration files are used by the SUNA for on-board processing and by SUNACom for data re-processing.

SUNA Manual
For SUNA running firmware version 2.5 or later
9. Firmware Upgrade

9. Firmware Upgrade

9.1 Firmware Upgrade Using SUNACom

The firmware upgrade can be initiated via the SUNACom. See section Upload Firmware of the SUNACom user manual for details.

9.2 Firmware Upgrade Using the Terminal Interface

The firmware upgrade is initiated via the `upgrade` command given at the command line. See section 4.2 Command Line Interface for details.

After the `upgrade` command, the SUNA's bootloader program executes. It reports to the command line using the `SATBLDR>` prompt.

Use the `w` command to initiate the firmware upload. Then, send the firmware file using the XMODEM protocol to the SUNA. Firmware files have the `sfw` file extension.

The bootloader rejects invalid or corrupt files. The user can check if the uploaded file is valid by issuing the `v` (verify) command.

After a valid firmware file has been uploaded, use the `a` command to let the bootloader execute the new firmware at power-up.

Then, power cycle the sensor. The new firmware will execute on the sensor.

10. Troubleshooting

10.1 *Sensor Is Not Responsive*

Check Power

Confirm that sufficient power reaches the sensor. Use a voltage meter to confirm that the power cable supplies 8–18 VDC (8–15 VDC for SUNA with an integrated wiper). See section 3.2 Specifications for the cable pin-out.

Reset Sensor

It is possible for the sensor to get stuck in an undefined state if its input power is sporadically out-of-range. In that case, the sensor should be powered down for 60 seconds, and then re-powered.

Check Power Consumption

Using a power supply with an accurate current indication will tell if the sensor is operating at all, and what operating state it may be in.

If the current is above 500 mA, the sensor is acquiring data. Inserting a piece of white paper into the sampling volume should show a bright spot, showing that the sensor lamp is operating.

If the current is above 5 mA, the sensor is in standby, and should respond to input over its serial input.

If the current is above 100 μ A, the sensor is in a low-power mode, and should respond to input over its serial input.

If the current is below 100 μ A, the sensor is not operating. Please contact Satlantic for further assistance.

Test Serial Cable

The sensor may appear to be non-responsive due to a faulty communication cable. The user can check the communication cable for continuity. See section 3.2 Specifications for the connector and cable pin-out.

Operating Mode

The sensor may be unresponsive to the received input because it is in an unexpected operating mode. For example, if the sensor is in SDI-12 mode, it will not respond to normal commands, or may not output data as in other operating modes.

If a connection via SUNACom does not succeed, a terminal emulator connection may be attempted.

Regardless if the operating mode, sending a \$ character to an operational sensor will

SUNA Manual
For SUNA running firmware version 2.5 or later
10. Troubleshooting

generate a response.

If there is no response, please contact Satlantic for further assistance.

10.2 Sensor Output Is Unexpected

Unexpected results can take many forms. A sensor that performed fine over a long period of time may suddenly report results that differ qualitatively or quantitatively from previous results.

Below are listed a few checks that may identify the problem.

Warning or Error Messages

In case of obvious problems, the sensor outputs error or warning log messages. If the sensor has internal logging capability, these are also logged to file. Monitoring the log messages or reviewing the content of the message log file may point to the origin of the problem.

Inaccurate Nitrate

Systematically inaccurate, but otherwise stable nitrate concentrations indicate the need to clean the sensor windows and to perform a reference update.

A reference update is best performed from within the SUNACom software. A reference update involves replacing the reference spectrum in the currently active calibration file by a new reference spectrum. Detailed instructions are provided in the SUNACom user manual.

If the concentrations inaccuracies persist, please contact Satlantic.

Imprecise or Noisy Nitrate, Low Spectral Intensity

If the nitrate concentration changes by more than 25 μM within a few samples while measuring a stable water sample, the measured spectral intensity is usually too low.

The spectral intensity of the sensor drops when the optical path gets obstructed or if optical component degrade.

Obstructions may be due to a change in the water content, or due to accumulation of matter (bio film, settled particles) in the sampling volume. If the spectral intensity remains low after cleaning of the sample volume, and especially the windows, please contact Satlantic.

High Humidity

If the relative humidity inside the sensor exceeds 90%, the sensor may have developed a leak, and needs to be returned to Satlantic for service. High humidity is problematic because it leads to failure of sensor components. Furthermore, high humidity may lead to condensation on optical components, making measurements inaccurate.

11. Accessories

11.1 Foul Guard

The foul guard is an optional accessory used for moored applications without an active pumping system. The foul guard consists of a strip of perforated copper plate that is formed around the SUNA sample volume. The guard is secured to the SUNA by a plastic clamp. The copper inhibits biofouling while the perforations allow passive flushing of the sample volume. When using the foul guard, the SUNA should be mounted so that the optical chamber is mounted at 90 degrees to the vertical. This orientation helps to prevent air bubbles and sediment from becoming trapped in the sample volume.

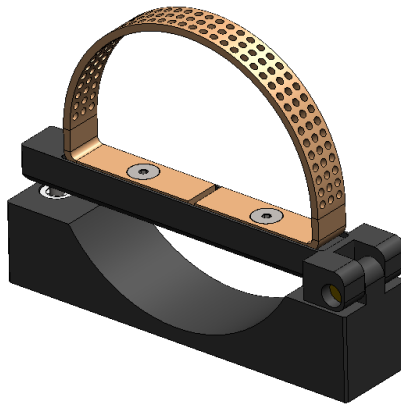

Illustration 6: Foul Guard

11.2 Wiper

The Zebra-Tech Hydro-Wiper is available as an integrated accessory. The wiper gently brushes the sample chamber to remove biological growth and particulate deposits from the optical path, ensuring consistent sampling conditions and data quality. The wiper reduces the need for site visits to manually clean the instrument, maintaining data quality through long deployments in harsh environments.

The integrated Hydro-Wiper is controlled by the SUNA and works with all operating modes such as periodic and polled modes. The wiper performs a single sweep before each sampling event. This option simplifies cabling and integration requirements for the user. The integrated Hydro-Wiper is not available for the Deep SUNA.

The wiper sweep angle is 90° for new models, 150° for old builds. For proper operation, the wiper movement must not be obstructed. The drawing below gives the minimum space requirements.

The wiper drive shaft features a slip mechanism, so the wiper arm can be manually moved if necessary. This also protects the wiper from damage if the wiper arm is subject to force during operation.



Illustration 7: SUNA with integrated wiper.

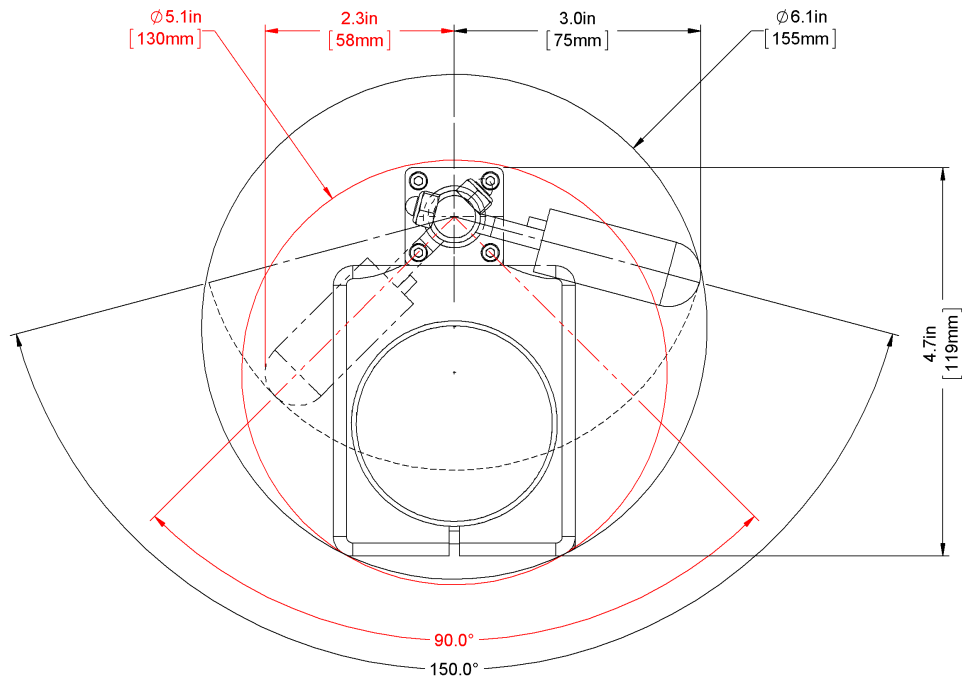

Illustration 8: Space requirements for the integrated wiper.

11.3 Flow Cell

The flow cell is an optional accessory used for moored applications with a pumped circulation system. It is also useful for calibration updates. The flow cell consists of a plastic cell that seals against the instrument housing and directs pumped flow across the optical path of the SUNA. The flow cell is equipped with a copper tube on the inlet port and a plastic barbed fitting on the outlet port that would be connected to the pump by flexible tubing. The kit includes additional elbow fittings that may be installed on the inlet or outlet ports to suit the physical arrangement of the instrument for deployment. The flow cell is secured to the SUNA by a plastic clamp. O-rings ensure the flow cell seals tightly around the sample volume.

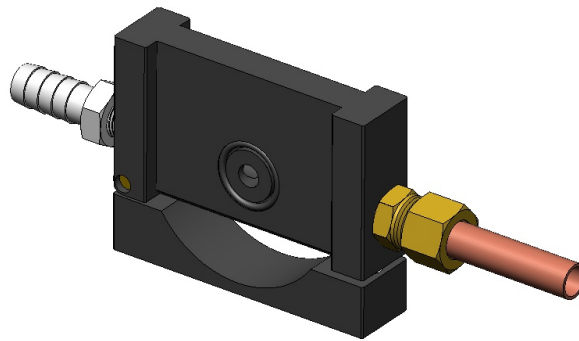

Illustration 9: Flow Cell

SUNA Manual
For SUNA running firmware version 2.5 or later
12. Maintenance

12. Maintenance

Before a deployment, and regularly during the deployment, the sensor windows have to be cleaned. At the same time, the reference spectrum should be updated.

A reference update is best performed from within the SUNACom software. A reference update involves replacing the reference spectrum in the currently active cal file by a new reference spectrum. Detailed instructions are provided in the SUNACom user manual.

After every deployment, the sensor must be cleaned with freshwater prior to storage. Corrosion resulting from failure to do so is not covered under warranty.

At regular intervals, check the sensor's internal humidity. If the humidity increases by more than a few percent per day, there is the possibility of a leak, and servicing is suggested.

At regular intervals, check the spectral intensity in pure water. While the optical intensity is expected to decrease over time, sudden changes in intensity may indicate problems with a sensor subsystem. Contact Satlantic if there is a sudden drop in intensity by more than 20%.

13. Safety And Hazards

13.1 Pressure Hazard

Warning! If you suspect that the sensor has flooded, use **extreme caution** around the sensor. If the sensor leaked at depth it might remain pressurized when recovered. If you suspect a flood, make sure to check the sensor for signs of pressurization. If the sensor is pressurized you may notice the gap between the end cap and pressure case look to be extended.

To relieve the sensor pressure, stand to the side of the sensor. Relieve the pressure by **very** slowly unscrewing the bulkhead connector. Be extremely careful, as if the sensor is pressurized the connector may be forced out of the housing with extreme force and at high velocity.

13.2 Electrical Hazard

Use care when connecting power supply cables to the sensor. A shorted power supply or battery can output maximum current, potentially harming the user or the equipment.

When transporting or shipping, install the dummy plug with locking sleeve on the sensor connector to prevent accidental shorting of the terminals.

Handle electrical terminations carefully, as they are not designed to withstand strain. Disconnect the cables from the bulkhead connector by pulling on the connector heads and not on the cables. Do not twist or wiggle the connector while pulling, as this will damage the connector pins.

Do not use petroleum-based lubricants on connectors. Connectors should be free of dirt and lightly lubricated before mating. We recommend applying a thin film of DC-111 silicone grease (made by Dow-Corning) on the male pins prior to connection.

While probing with a voltmeter, take care not to short the probes. Shorts can damage equipment, create safety hazards, and blow embedded fuses.

13.3 Deployment and Recovery Safety

Do not leave the sensor in direct sunlight. Extreme heat (35°C or greater) can cause damage.

When deploying a sensor in water, do not leave it unattended. Boat drift can entangle the cable and cause damage or sensor loss.

Never lift the sensor by pulling it from the cable. This can cause damage to the bulkhead connectors, cables, and splices.

Dummy connectors should be replaced as soon as the equipment is retrieved. This will help protect the bulkhead connector from dirt and damage.

SUNA Manual
For SUNA running firmware version 2.5 or later
14. Warranty

14. Warranty

14.1 Warranty Period

All Satlantic equipment is covered under a one-year parts and labor warranty from date of purchase.

14.2 Restrictions

Warranty does not apply to products that are deemed by Satlantic to be damaged by misuse, abuse, accident, or modifications by the customer. The warranty is considered void if any optical or mechanical housing is opened. In addition, the warranty is void if the warranty seal is removed, broken or otherwise damaged.

14.3 Provisions

During the one year from date of purchase warranty period, Satlantic will replace or repair, as deemed necessary, components that are defective, except as noted above, without charge to the customer. This warranty does not include shipping charges to and from Satlantic.

14.4 Returns

To return products to Satlantic, whether under warranty or not, contact the Satlantic Customer Support Department and request a Returned Material Authorization (RMA) number and provide shipping details.

All claims under warranty must be made promptly after occurrence of circumstances giving rise thereto and must be received by Satlantic within the applicable warranty period. Such claims should state clearly the product serial number, date of purchase (and proof thereof) and a full description of the circumstances giving rise to the claim. All replacement parts and/or products covered under the warranty period become the property of Satlantic.

14.5 Liability

IF SATLANTIC EQUIPMENT SHOULD BE DEFECTIVE OR FAIL TO BE IN GOOD WORKING ORDER THE CUSTOMER'S SOLE REMEDY SHALL BE REPAIR OR REPLACEMENT AS STATED ABOVE. IN NO EVENT WILL SATLANTIC BE LIABLE FOR ANY DAMAGES, INCLUDING LOSS OF PROFITS, LOSS OF SAVINGS OR OTHER INCIDENTAL OR CONSEQUENTIAL DAMAGES ARISING FROM THE USE OR INABILITY TO USE THE EQUIPMENT OR COMPONENTS THEREOF.

SUNA Manual
For SUNA running firmware version 2.5 or later
15. Contact Information

15. Contact Information

If you have any problems, questions, suggestions, or comments about the sensor or manual, please contact us.

Call us direct at [+1 902 492 4780](tel:+19024924780) between 8 AM and 5 PM, Atlantic Time (GMT - 0400) or send us an e-mail any time at info@satlantic.com. For specific requests such as price quotations, product support, or return materials authorization (RMA) for repair or recalibration, please select the applicable contact:

Sales: <http://satlantic.com/contact-sales> or sales@satlantic.com
 Support <http://satlantic.com/contact-support> or support@satlantic.com
 Service: <http://satlantic.com/rma>

Written inquires and returns may be sent to:

Satlantic LP
 Richmond Terminal- Pier 9
 3481 North Marginal Road
 Halifax NS B3K 5X8
 CANADA

Satlantic is not open for business during Canadian statutory holidays:

New Year's Day	January 1
Good Friday	The Friday before Easter Sunday
Victoria Day	The first Monday before May 25
Canada Day	July 1
Civic Holiday	The first Monday in August
Labor Day	The first Monday in September
Thanksgiving Day	The second Monday in October
Remembrance Day	November 11
Christmas Day	December 25
Boxing Day	December 26

SUNA Manual
For SUNA running firmware version 2.5 or later
16. Revision History

16. Revision History

- Revision A, 2013-11-01: Initial release.
- Revision B, 2014-05-02: 3.2.3 Refer for T-S-Correction to SUNACom.
5.2 Expand data file type explanation.
7.1 Fix typo in frame table, nitrate units.
11.2. Remove external wiper; enlarge wiper images.
- Revision C, 2014-05-15: 3.2.3 Add μM nitrate to mg/l nitrogen conversion factor.
- Revision D, 2014-09-16: 3.2.1 Add storage and operating temperature range.
3.2.2 Add 1 A current requirement of power supply.
4.2.3 Add acquisition file type duration setting.
4.2.3 Add minimum interval for external device.
4.2.5 SDI-12 operation: wiper and internal logging.
5.4.1 Specify 1 PSU limit for freshwater processing.
- Revision E, 2014-12-01: 4.2.1 Added special swipewiper command.
4.2.3 Remove unused legacy configuration parameters.
4.2.3 Add Custom Identification configuration parameter.